



SS223HP

SAFARI ARMAX SNORKEL

To Suit: TOYOTA HILUX (Jan 2026 onwards)
 2.8L Turbo Diesel D-4D (1GD-FTV Engine)
 2.8L Turbo Diesel D-4D - 48V Hybrid (1GD-FTV)



14/05/2026

Parts List

ITEM	PART NO.	DESCRIPTION	QTY
1	323-133-600	BODY - SNORKEL (SS223HP)	1
2	000-135-980	ARMAX AIR RAM ASSEMBLY	1
3	000-951-480	SCREW – S/T – 4.2MM X 13MM (BLACK)	4
4	323-032-600	BRACKET - UPPER MOUNTING	1
5	000-002-100	BOLT - HEX - 6mm x 1.0 x 14mm (SEMS) - S/S	2
6	000-951-300	SCREW - S/T - 4.2mm x 16mm - S/S	3
7	000-960	INSERT - PLASTIC	3
8	000-110	STUD - 8mm x 1.25 x 25mm - S/S	6
9	000-311-300	WASHER - BODY - 8mm x 30mm - S/S	6
10	000-205-300	NUT - NYLOC - 8mm x 1.25mm - S/S	6
11	323-024-000	HOSE - AIR ENTRY	1
12	000-910	CLAMP - HOSE - 90/110mm - S/S	1
13	000-1912	CLAMP - HOSE - 110/130mm - S/S	1
14	323-017-600	TEMPLATE - GUARD PANEL	1



SS223HP

SAFARI ARMAX SNORKEL

To Suit: TOYOTA HILUX (Jan 2026 onwards)
 2.8L Turbo Diesel D-4D (1GD-FTV Engine)
 2.8L Turbo Diesel D-4D - 48V Hybrid (1GD-FTV)

Installation Guide

Fitment to:

- Right Hand Side

Fitting Time:

- 180min

Special Tools:

- Body Saw (reciprocating)
- Step Drill
- Die Grinder
- 4.0, 8.0 & 10mm Drill Bits
- Sikaflex 227 Adhesive Sealant
- Loctite 243 (thread lock)
- Masking Tape
- Touch-up paint

Prior to commencing the installation, it is the installer's responsibility to verify that all components and particularly the template (Item 14) are correct.

1

Remove and discard

- Air intake ducting
- Air Deflector (Optional)

Note: Air deflector can be re-installed after snorkel installation if preferred.

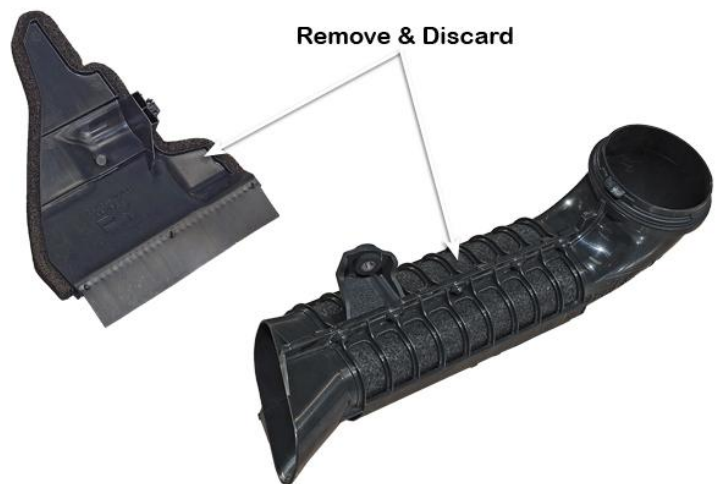

2

Remove and discard the perforated section from the guard panel template (Item 14) as shown.

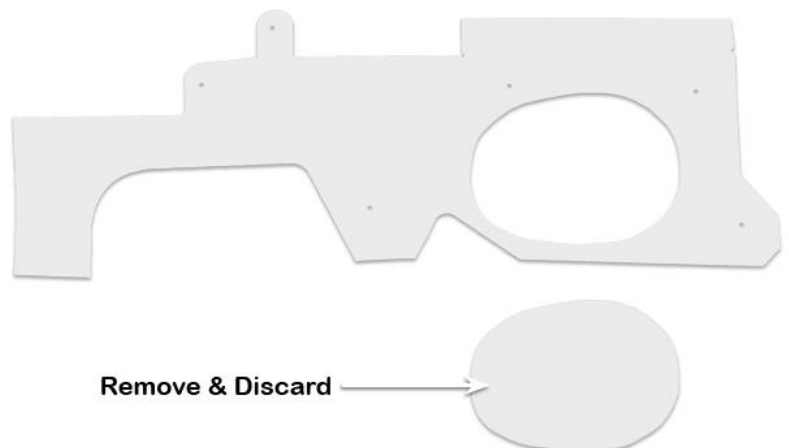

3

Align the guard panel template (Item 14) to the upper and rear edges of the right hand guard panel as shown.

Tape the template to the guard panel with masking tape.

Mark all hole positions and the cut-out section with a felt tip pen.

Remove the template.

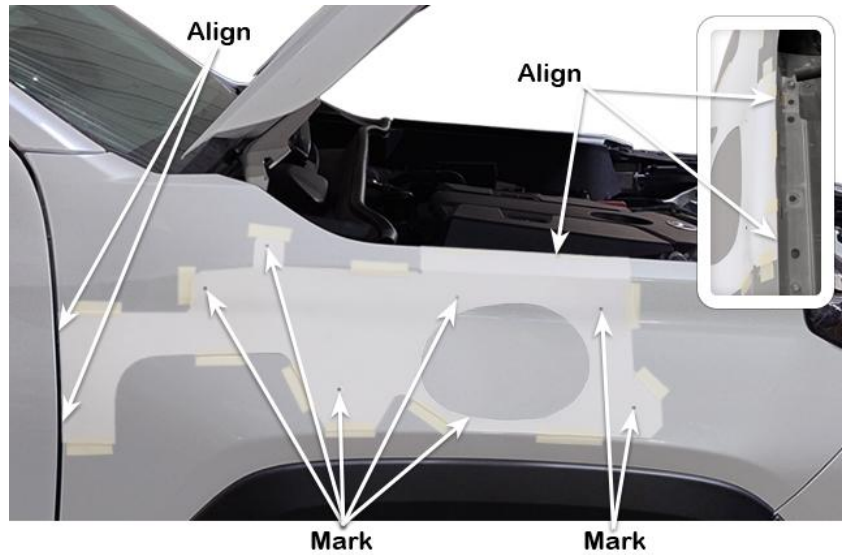

4

Drill a pilot hole for each of the marked hole positions.

Drill two 10mm diameter holes within the snorkel outlet cutout section as start entry points for the body saw, use the body saw to cut away the marked section of the guard panel.

Use a step drill to drill the six mounting holes to 16mm diameter.

Deburr and paint all holes.

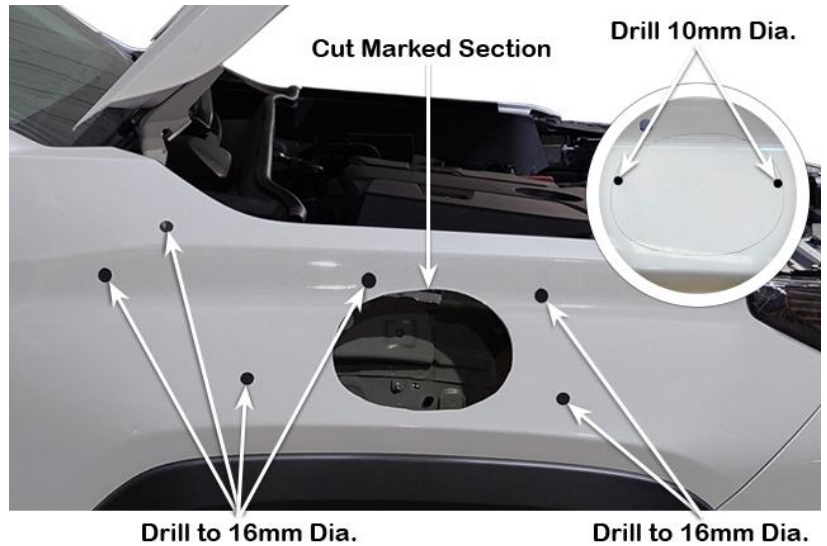

5

Using a body saw, cut off the lower section of the front air inlet duct mounting bracket from the inner guard panel, as shown.

Deburr and paint the cut edge to prevent rust.



Trim Mount Bracket

NEW ZEALAND INSTALLATIONS ONLY :

Safari have developed 2 methods of Snorkel A pillar attachment, for the conventional method please proceed with the current document alternatively please see the link below for further instructions.

www.safari4x4.co.nz/apillarmounting

6

Install the upper mounting bracket (Item 4) to the snorkel body (Item 1) with hex bolts (Item 5).

Apply Loctite 243 to each of the stainless steel mounting studs (Item 8) and install the studs finger tight into the snorkel body (Item 1) mounting inserts as shown.

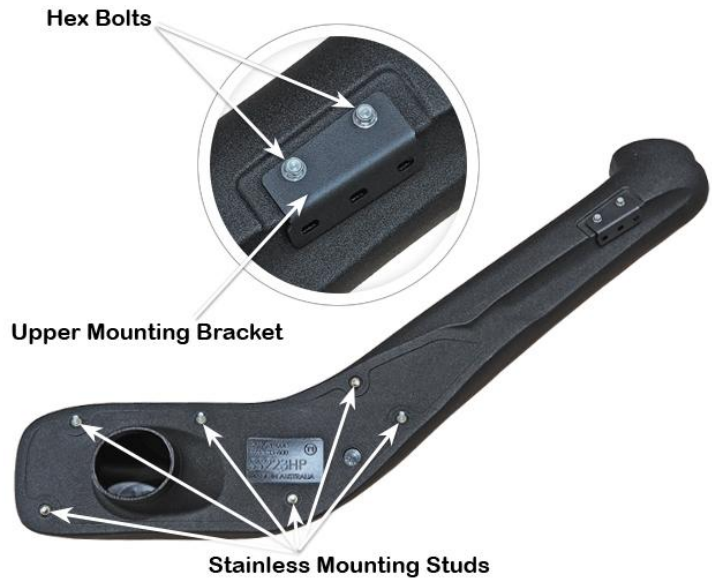

7

Locate the four dimples around the inlet of the snorkel body.

Drill a 2.0mm diameter pilot hole at each of the four dimple locations as shown.

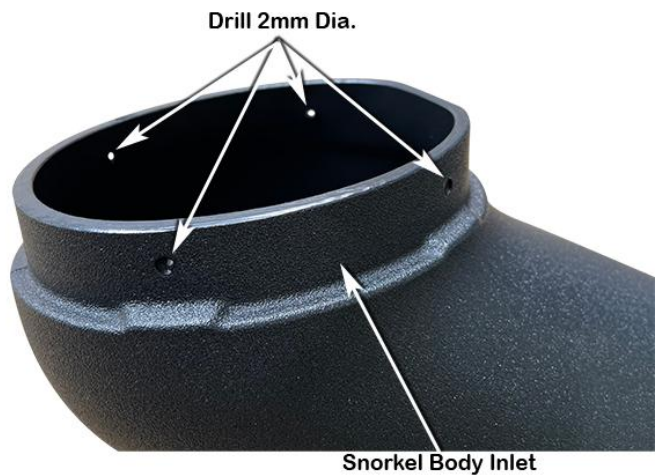

8

Place a strip of masking tape along the A-pillar panel.

Carefully install the snorkel body (Item 1) to the guard panel.

With the snorkel body correctly positioned on the vehicle, accurately mark the position of the upper mounting bracket (Item 4) onto the masking tape.

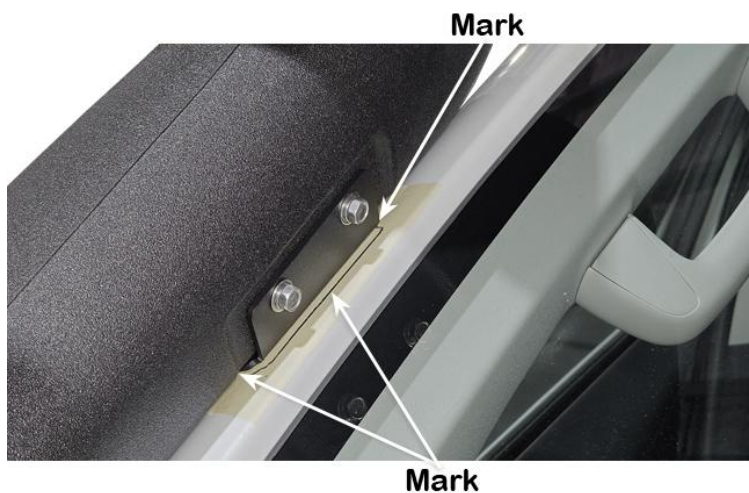

Remove the snorkel body (Item 1) from the vehicle and remove the upper mounting bracket (Item 4) from the snorkel body.

Position the upper mounting bracket (Item 4) onto the A-pillar and align the bracket with the marked bracket outline.

Mark the centre of the three mounting hole positions with a felt tip pen.

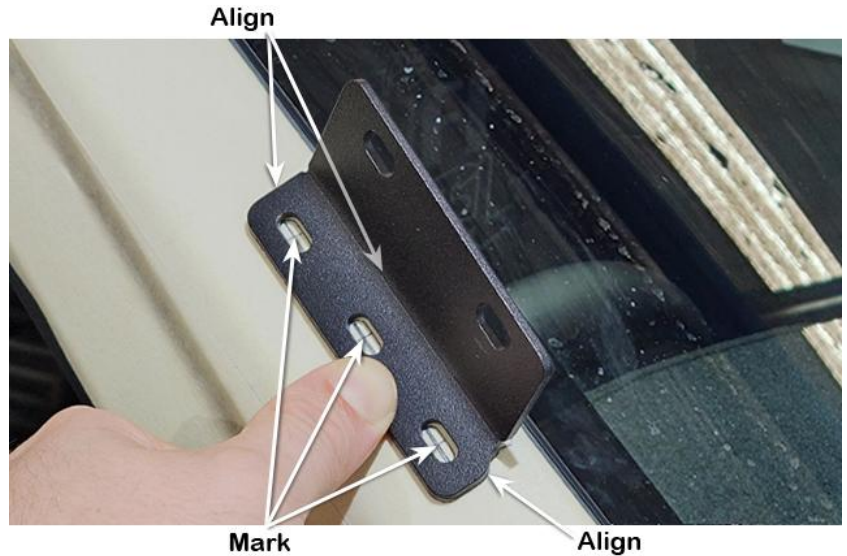

Drill a pilot hole at each of the three marked hole positions. Drill each hole position to 8mm diameter using an 8mm drill bit. Deburr and paint holes.

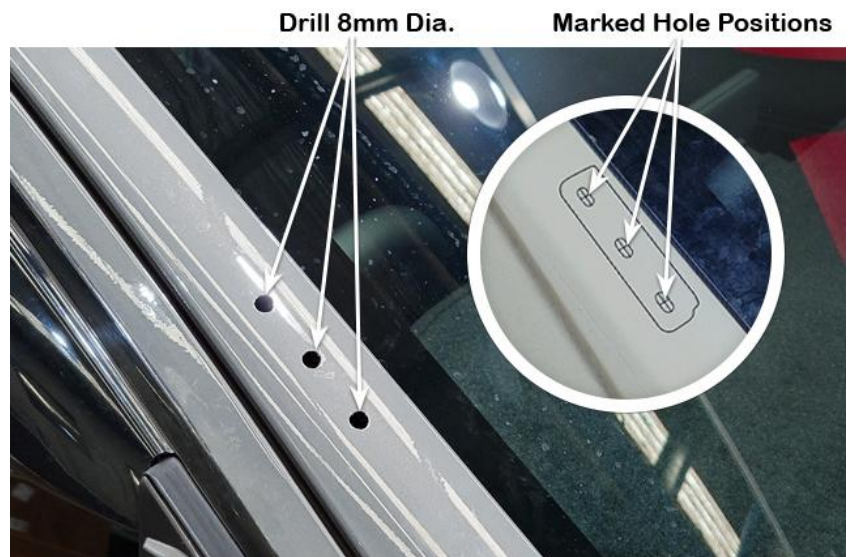

Install the plastic inserts (Item 7) into the 8mm diameter holes in the A-pillar.

Secure the upper mounting bracket (Item 4) to the A-pillar with three self-tapping screws (Item 6).

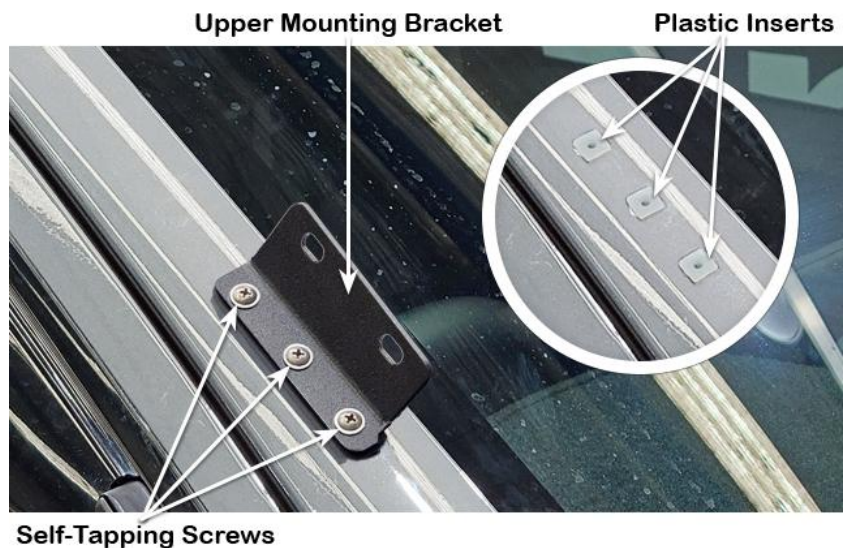

Install the air entry hose (Item 11) through the hole in the inner guard panel.

Loosely install a 90/110mm hose clamp (Item 12) onto the outlet of the air entry hose and a 110/130mm hose clamp (Item 13) onto the inlet of the air entry hose.

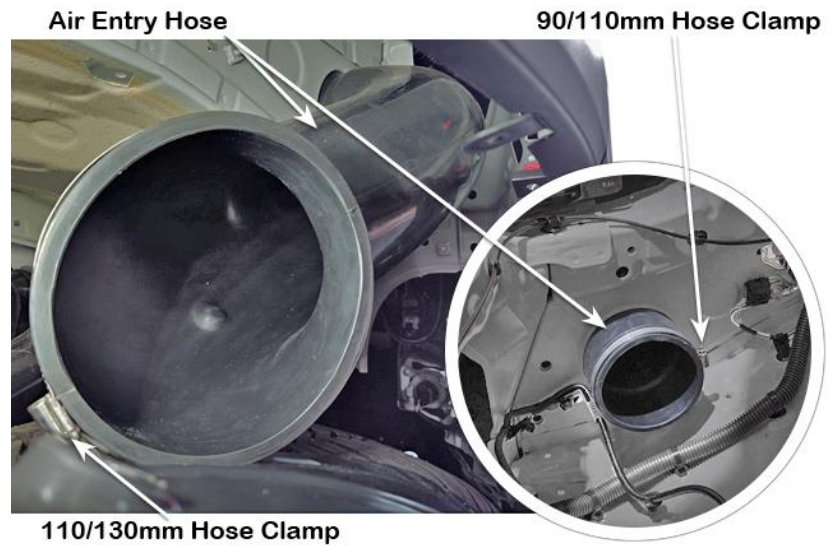

Carefully remove and discard the pre-spinner assembly from the air cleaner base inlet.



The pre-spinner chamber must be completely removed from the air cleaner base inlet, using the necessary tools carefully remove the chamber as shown.

Step 1; Using a die grinder with a cut-off disc, remove as much of the internal tube as possible (60mm approximately), care must be taken when using the cut-off disc not to cut through the outer and inner walls of the air cleaner base.

Step 2; Using the body saw cut away as much of the end section of the chamber as possible.

Step 3; Using a die grinder with a suitable burr, carefully remove the end section of the chamber.

Step 4; Use a file to neatly remove the remaining material from the end of the chamber.

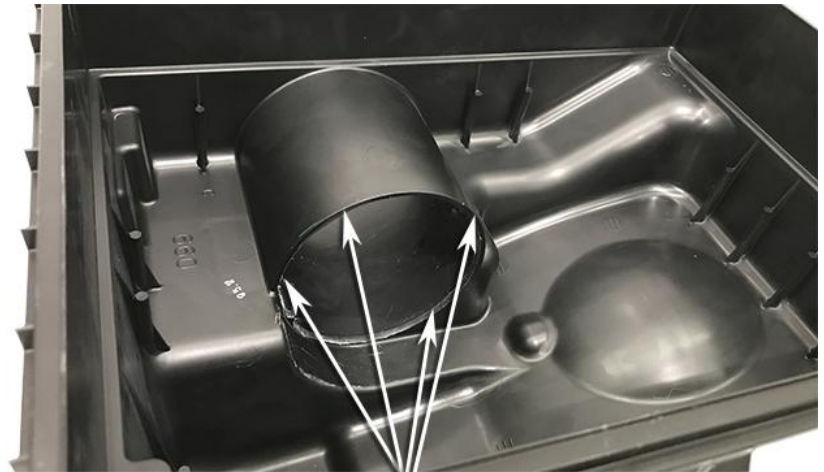

Remove End Section of Pre Spinner Chamber

INSTALLER OPTION :

The air cleaner base contains a drain valve and drain hole as shown. The drain valve and drain hole can permit water to enter the air intake.

Safari advises that the drain valve and drain hole should be sealed to ensure a watertight installation.

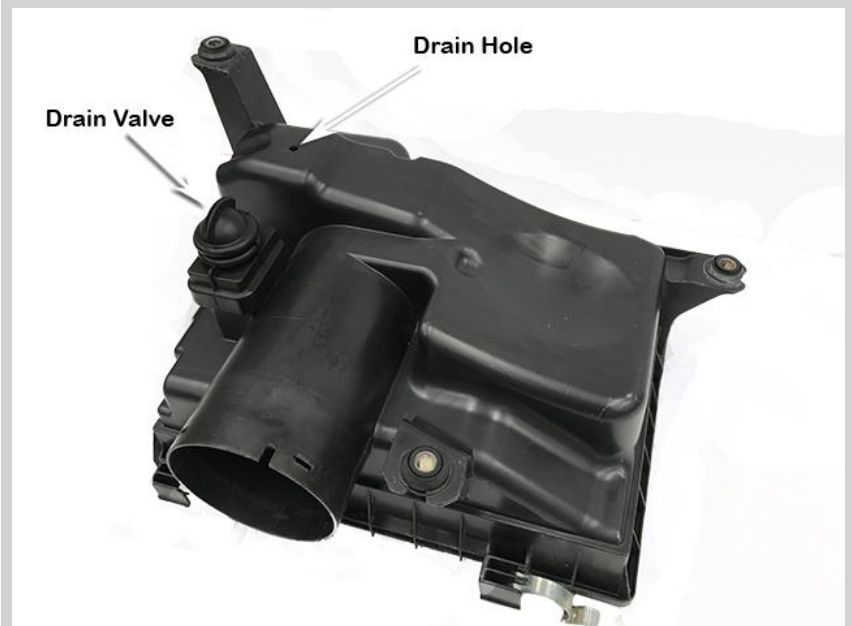

16

Re-install the modified air cleaner housing, guiding the air cleaner inlet into the air entry hose.

Fasten the air cleaner housing using standard mounting bolts.

Align the inlet of the air entry hose (Item 11) to the snorkel body outlet cutout in the guard panel, gently tighten the 90/110mm hose clamp (Item 12) at the air cleaner base inlet to keep the air entry hose in position.

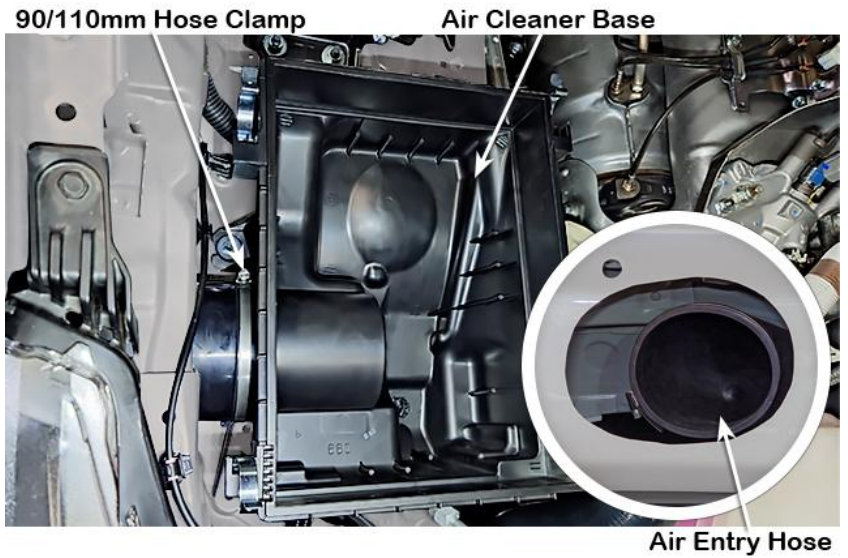

17

Install the ARMAX air ram assembly (Item 2) onto the snorkel body.

Align the ARMAX air ram assembly mount holes with the four pre-drilled 2mm diameter holes in snorkel body inlet.

Secure the ARMAX air ram (Item 2) to the snorkel body (Item 1) with four black self-tapping screws (Item 3).



18

Carefully install the snorkel body (Item 1) to the guard panel, guiding the snorkel body outlet snout into the air entry hose (Item 11), align the snorkel body to guard panel and upper mounting bracket.

When correctly aligned, fasten the snorkel body to the guard panel with body washers (Item 9) and nyloc nuts (Item 10).

Fasten the snorkel body to the upper mounting bracket with hex bolts (Item 5)



19

Align the air entry hose for best fitment (*Ensure the air entry hose is installed closely against the shoulder of the snorkel body outlet*). Correctly position the 90/110mm & 110/130mm hose clamps (Item 12 & 13) at either end of the air entry hose, as shown, and tighten.



110/130mm Hose Clamp

90/110mm Hose Clamp

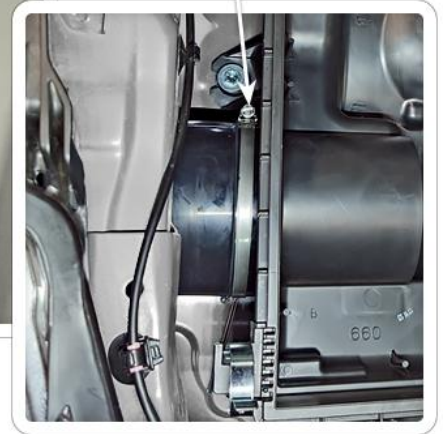

20

Install the guard liner, mud flap, air cleaner element, air cleaner lid, reconnect sensor wiring, install the RH guard upper plastic trim and any other items that may have been removed during the snorkel installation process.

21

N.B: It is the installer's responsibility to ensure that all connections are water tight.