

# SS742HF

NISSAN D23 NAVARA (NP300)

MY21 - MY25 Facelift Model

2.3Ltr Intercooled Twin Turbo (YS23DDTT Engine)

Built: Nissan Motor Co. Thailand

**NOTE: WIDE BODY VEHICLES ONLY**



06/05/2026

## Parts List

ITEM	PART NO.	DESCRIPTION	QTY
1	435-133-100	BODY - SNORKEL (SS741HF)	1
2	000-135-800	3 ½" AIR RAM ASSEMBLY	1
3	435-032-000	BRACKET - UPPER MOUNTING	1
4	000-002-100	BOLT - HEX - 6mm x 1.0 x 14mm (SEMS)	5
5	000-951-300	SCREW - S/T - 4.2mm x 16mm - S/S	3
6	000-960	INSERT - PLASTIC	3
7	000-131	STUD - 8mm x 1.25 x 25mm - S/S (GRUB SCREW)	4
8	000-010	BOLT - HEX - 8mm x 1.25 x 12mm - S/S	2
9	000-311-300	WASHER - BODY - 8mm x 30mm - S/S	6
10	000-305	WASHER - STAR - 8mm - S/S	2
11	000-205-300	NUT - NYLOC - 8mm x 1.25mm - S/S	4
12	435-024-200	HOSE - AIR ENTRY	1
13	435-217-000	TEMPLATE - AIR CLEANER	1
14	435-025-000	PLATE - CLAMPING (upper)	1
15	435-025-100	PLATE - CLAMPING (side RH)	1

16	435-025-200	PLATE - CLAMPING (side LH)	1
17	435-025-300	PLATE - CLAMPING (lower)	1
18	000-958-175	POP RIVET - 4mm x 17mm	10
19	000-958-750	POP RIVET - 4mm x 20mm (Splade)	4
20	000-300-350	WASHER - BODY - 4mm x 12mm S/S	7
21	435-959-000	CAP - AIR INLET BLANK-OFF	1
22	000-906	CLAMP - HOSE - 50/70mm - S/S	1
23	000-908	CLAMP - HOSE - 70/90mm - S/S	1
24	435-089-000	BRACKET - ECU RELOCATION	1
25	435-089-100	BRACKET - ECU SUPPORT	1
26	435-089-400	BRACKET - RELAY BOX RELOCATION	1
27	000-002	BOLT - HEX - 6.0mm x 1.0mm x 16mm - (Zinc)	1
28	000-004	BOLT - HEX - 6.0mm x 1.0mm x 25mm - (Zinc)	4
29	000-310-100	WASHER - BODY - 6.0mm x 15mm - (Zinc)	8
30	000-204	NUT - NYLOC - 6.0mm x 1.0mm - S/S	3
31	000-353-480	WASHER - BODY - 6.0mm x 18mm - (Zinc)	6
32	435-967-000	PLATE - INNER GUARD SUPPORT - S/S (Pressed)	1
33	000-1020-300	BOLT - B/H CAP SCREW - 5.0mm x 0.8 x 12mm - S/S	4
34	000-1022-300	BOLT - B/H CAP SCREW - 5.0mm x 0.8 x 16mm - S/S	3
35	000-320-350	WASHER - BODY - 5.0mm x 15mm - S/S	14
36	000-221-300	NUT -NYLOC - 5.0mm x 0.8mm - S/S	7
37	000-958-625	POP RIVET - 4.8mm x 10mm (Black anodised)	1
38	000-914/B	CLAMP - HOSE SIZE 56 (BLACK)	1
39	435-017-400	TEMPLATE - INNER GUARD	1
40	435-017-100	TEMPLATE - GUARD PANEL	1

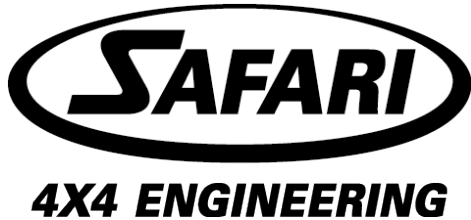

# SS742HF

NISSAN D23 NAVARA (NP300)  
MY21 - MY25 Facelift Model

2.3Ltr Intercooled Twin Turbo (YS23DDTT Engine)

Built: Nissan Motor Co. Thailand

**NOTE: WIDE BODY VEHICLES ONLY**

## Installation Guide

### Fitment to:

- Right Hand Side

### Fitting Time:

- 210min

### Special Tools:

- Body Saw (reciprocating)
- 90 Deg Drill
- Step drill
- Masking Tape
- Grinder / Files
- 4.5, 5.0, 5.5mm Drill Bits
- Pop Rivet Gun
- Loctite 243 (thread lock)
- Touch-up paint
- Sikaflex 227 Adhesive Sealant

**Prior to commencing the installation, it is the installer's responsibility to verify that all components and particularly the template (Item 39 & 40) are correct.**

1

Disconnect the negative battery terminal.

Remove the following in accordance with the factory service manual:

- RHS mud flap
- RHS Inner guard liner
- Air cleaner assembly
- Washer Bottle Assembly
- ECU Module
- Air Cleaner Mounting Bracket
- Relay Box Mounting Bracket
- Earth strap

2

Remove and discard

- Air intake Duct & rubber seal
- ECU Mounting Bracket

Remove & Discard



3

Remove and discard the perforated section from the guard panel template (item 40) as shown.

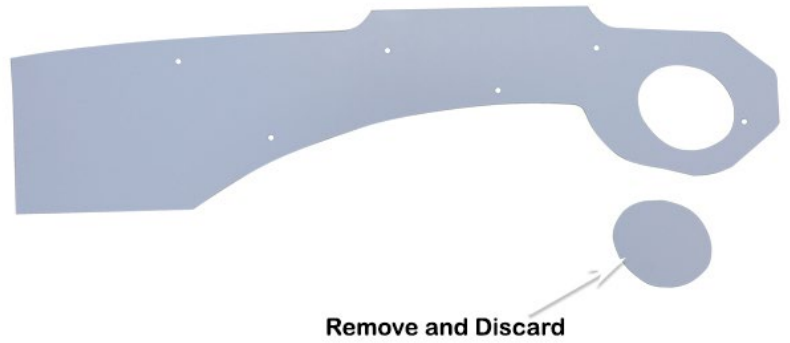

4

Align the guard panel template (item 40) to the upper and rear edges of the right hand guard panel as shown.

Tape the template to the guard with masking tape.

Mark all hole position and the snorkel body outlet hole with a felt tip pen.

Remove the template.

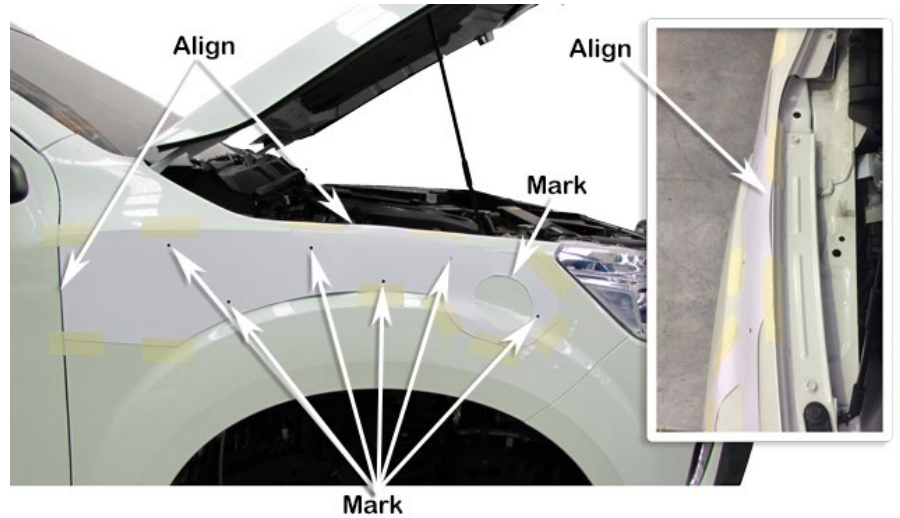

5

Drill a pilot hole for each marked hole position.

Use a step drill to drill the six mounting hole positions to 16mm diameter.

Using the body saw, cut the snorkel body outlet hole in the guard panel.

Deburr and paint holes to prevent rust.

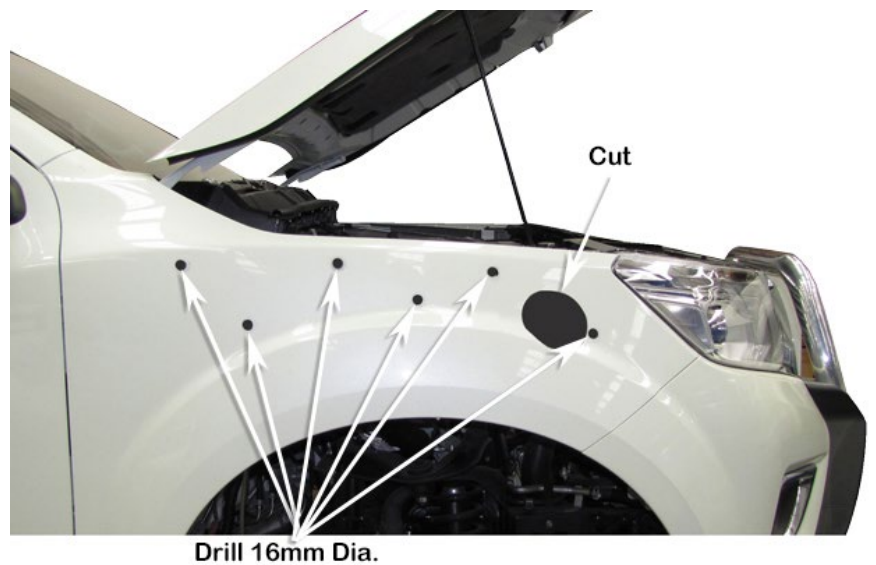

## NEW ZEALAND INSTALLATIONS ONLY:

Safari have developed 2 methods of Snorkel A-pillar attachment, for the conventional method please proceed with the current document alternatively please see the link below for further instructions.

[www.safari4x4.co.nz/apillarmounting](http://www.safari4x4.co.nz/apillarmounting)

6

Install the upper mounting bracket (item 3) to the snorkel body (item 1) with hex bolts (item 4).

Apply Loctite 243 to the front and top three brass snorkel body mounting inserts, using a 4mm Allen key install the stainless steel mounting studs (item 7) finger tight into the four snorkel body (item 1) mounting inserts shown.

**NB: Do not install studs into the centre and rear lower snorkel body mounting inserts.**

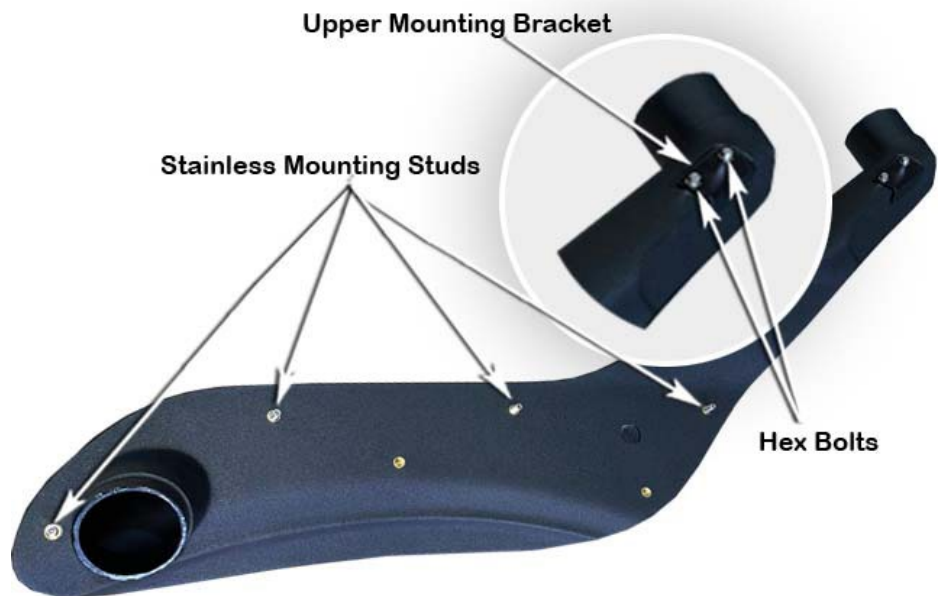

7

Place a strip of masking tape along the A-Pillar panel.

Carefully install the snorkel body (Item 1) to the guard panel.

With the snorkel body correctly positioned, mark the outline of the upper mounting bracket (Item 3) onto the masking tape.



Remove the snorkel body (Item 1) from the vehicle and remove the upper mounting bracket (Item 3) from the snorkel body.

Position the upper mounting bracket onto the A-Pillar and align the bracket with the marked bracket outline.

Mark the three mounting hole positions with a felt tip pen.

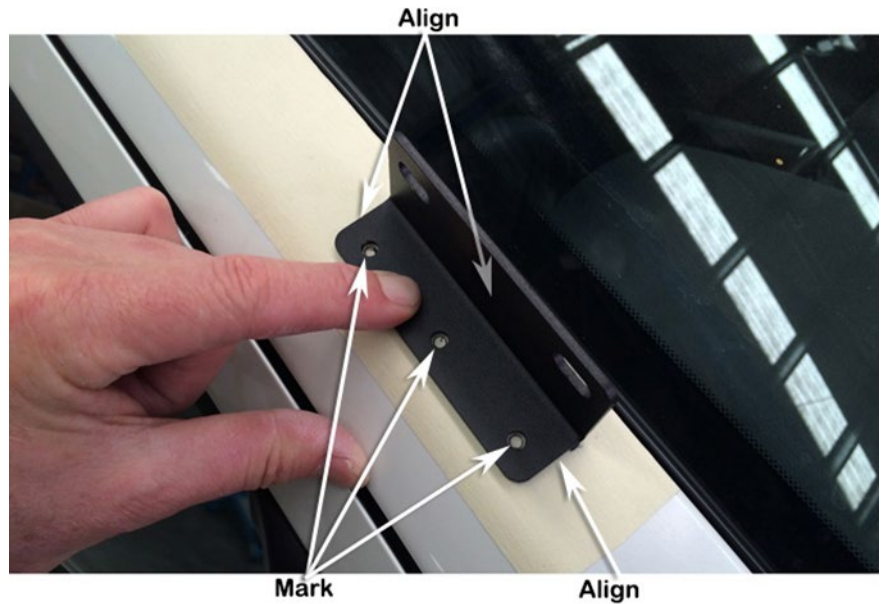

Drill a pilot hole at each of the three marked hole positions. Drill each hole position to 8mm diameter with a step drill or 8mm drill bit.

Deburr and paint holes to prevent rust.

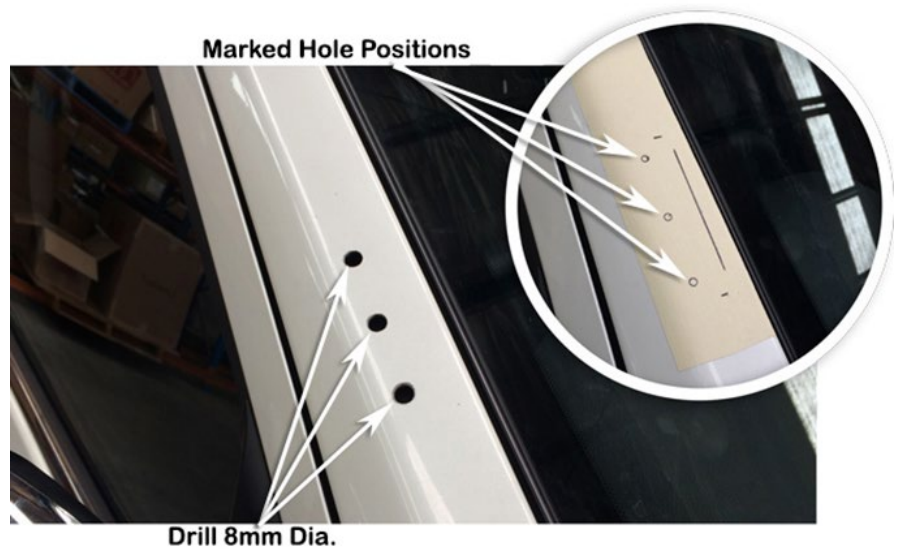

Install the plastic inserts (Item 6) into the 8mm diameter holes in the A-pillar.

Secure the upper mounting bracket (Item 3) to the A-pillar with three stainless steel self-tapping screws (Item 5).

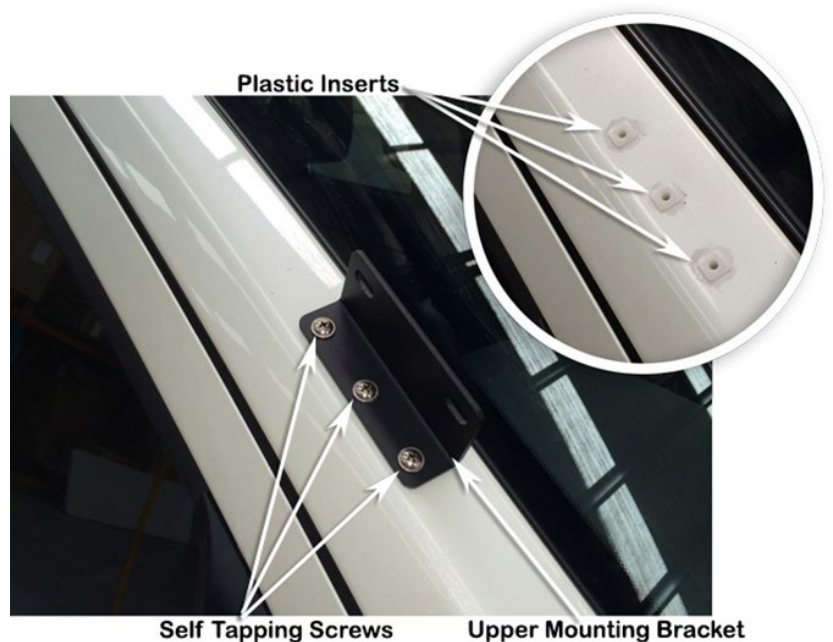

Unclip the wiring loom from the mounting holes in wheel arch panel, move the wiring loom away from the inner guard panel and tape to avoid the loom from being damaged during the installation.

Align the inner guard template onto the lower left hand stud and the two M6 captive nuts as shown.

Attach the template using two 6mm hex bolts.

Using a felt tip pen, mark the inner guard cut-out onto the inner guard panel as shown.

Remove the template.

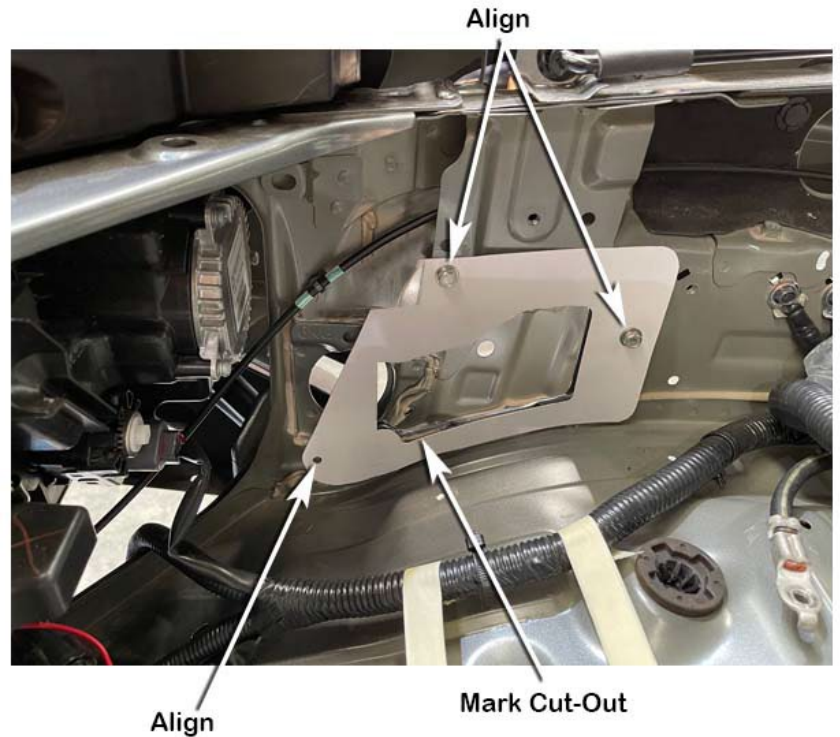

With the wiring loom taped away from the inner guard panel.

Using the body saw, cut the hole in the inner guard panel as marked in step 11.

Deburr the cut hole.



**Cut and Deburr Inner Guard Hole**

Using the 90 deg drill, drill out the lower spot weld shown, try to avoid drilling right through all the adjoining panels, using the body saw or a small cut off disc, cut off the upper and lower pieces of inner guard panel as shown.

Deburr the cut panel.

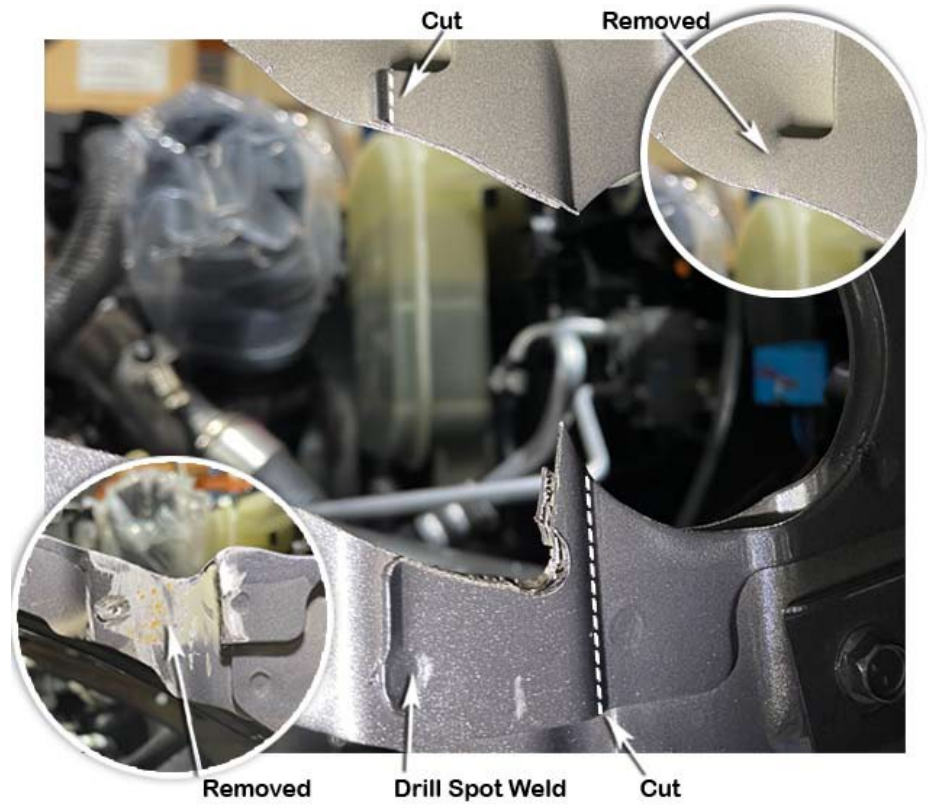

Install the inner guard support plate (item 32) to the inner guard panel, align the support plate to the inner guard panel and secure to the M6 captive nut in the inner guard panel with a M6 hex bolt (item 4).

With the support plate aligned to the inner guard panel, using a 90 deg drill, drill the lower centre hole with a 5.0mm drill bit.

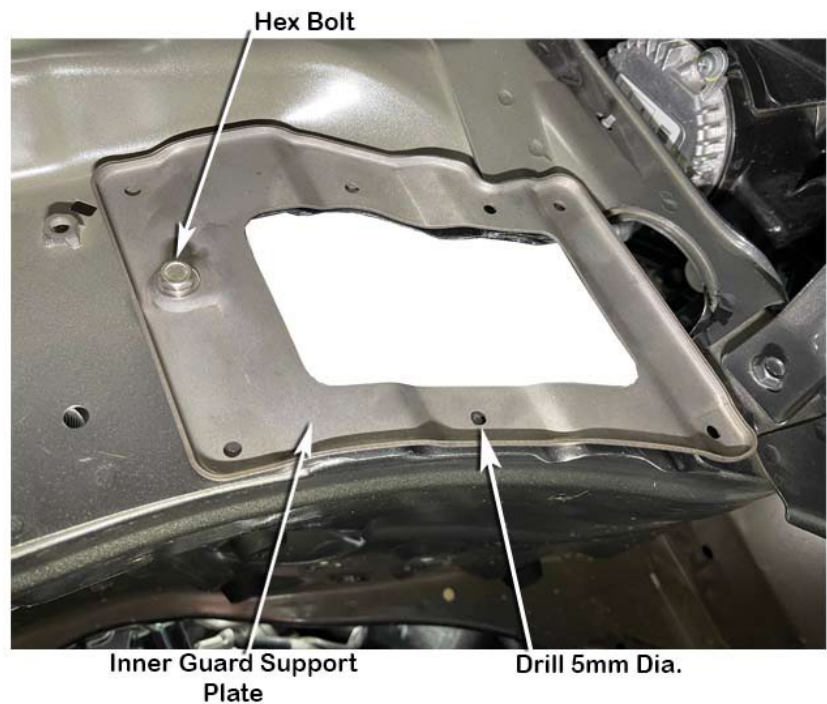

Install a M5 x 12mm B/H cap screw (item 33) with a M5 body washer (item 35) installed through the inner guard support plate and 5.0mm dia hole, secure with a M5 body washer and M5 nyloc nut (item 36).

Using the 90 deg drill, drill the top centre hole through the inner guard panel with a 5.0mm drill bit.

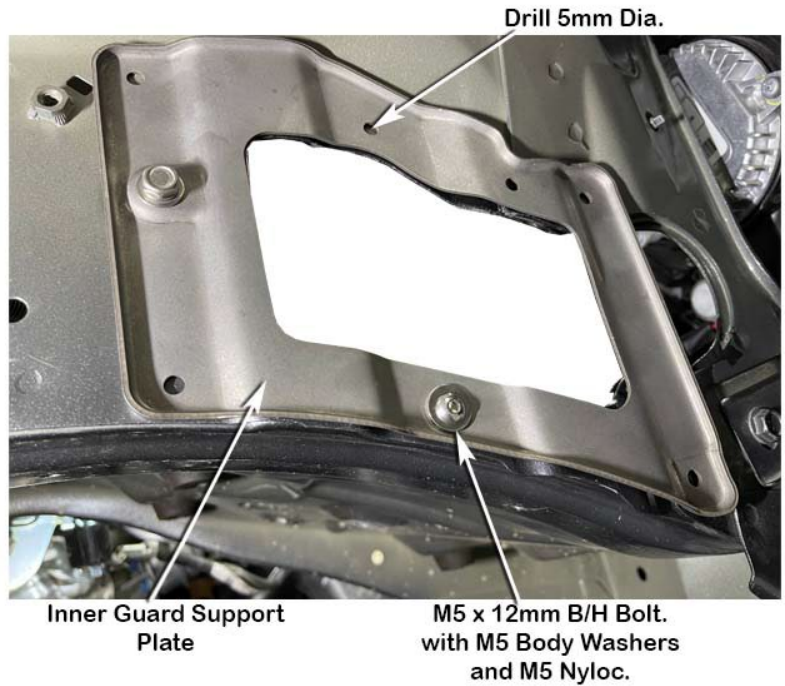

Install a M5 x 12mm B/H cap screw (item 33) with a M5 body washer (item 35) installed through the top centre hole of the inner guard support plate and 5.0mm dia hole, secure with a M5 body washer and M5 nyloc nut (item 36).

Using the 90 deg drill, drill the top front hole through the inner guard panel with a 5.0mm drill bit.

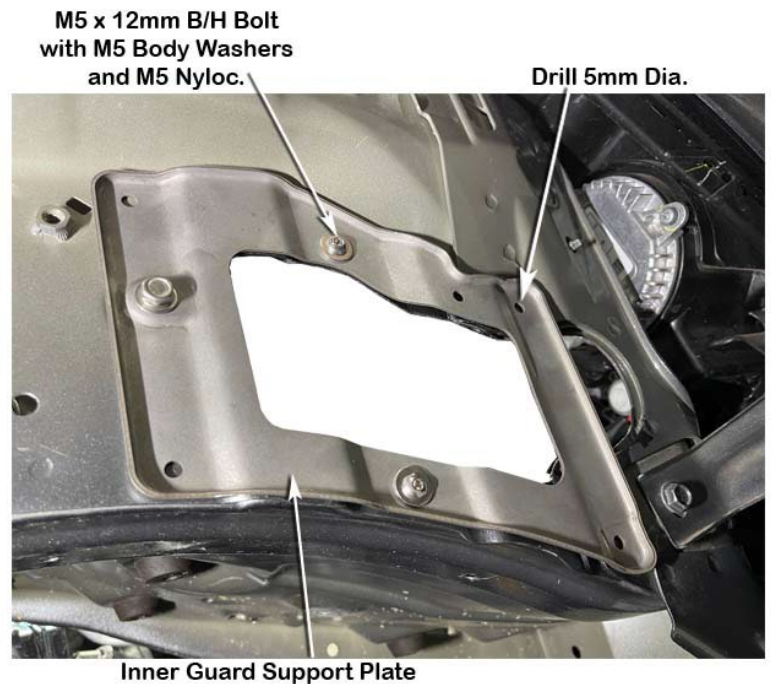

Install a M5 x 16mm B/H cap screw (item 34) with a M5 body washer (item 35) installed through the top front hole of the inner guard support plate and 5.0mm dia hole, secure with a M5 body washer and M5 nyloc nut (item 36).

M5 x 16mm B/H Bolt  
with M5 Body Washers  
and M5 Nyloc.

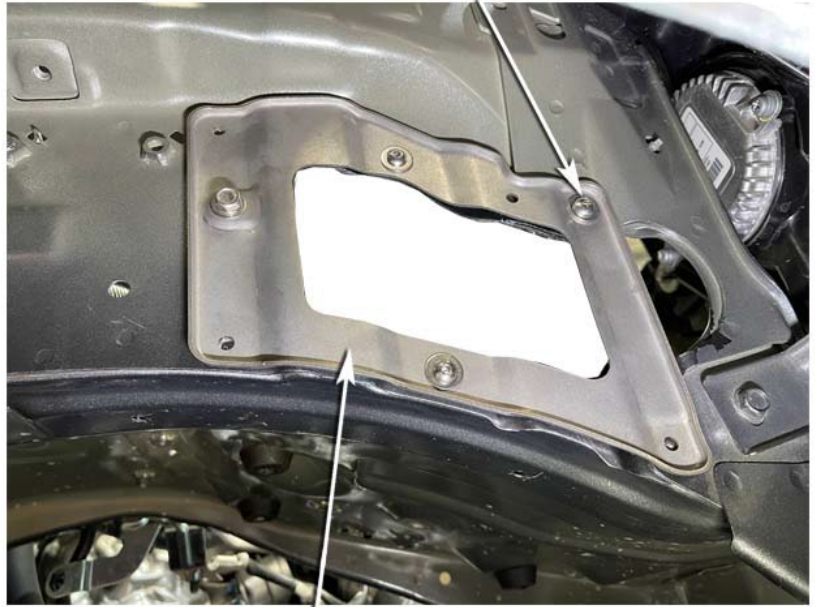

Inner Guard Support Plate

With the inner guard support plate (item 32) now secured to the inner guard panel in four places, using the 90 deg drill, drill the remaining four hole positions with a 5.0mm drill bit.

Remove the inner guard support plate and drill all seven mounting holes to 5.5mm.

Deburr the inner guard cut out and all holes, prime and paint to prevent rust.

Drill 5mm Dia.



Inner Guard Support Plate

Drill 5mm Dia.

Apply a generous amount of Sikaflex sealant to the inner guard panel, install the inner guard support plate (item 32) to the inner guard panel, secure the inner guard support plate to the inner guard panel with M6 hex bolt (item 4), four M5 x 12mm and three M5 x 16mm B/H cap screws (item's 33 & 34), M5 body washers (item 35) and M5 nyloc nuts (item 36).

Clean up any excess Sikaflex to ensure a neat finish.

Un-tape the wiring loom and reclip back into position.

**Note: It is critical that the correct length bolts are installed in the correct hole positions and the bolts are install through from the inner guard support plate side.**

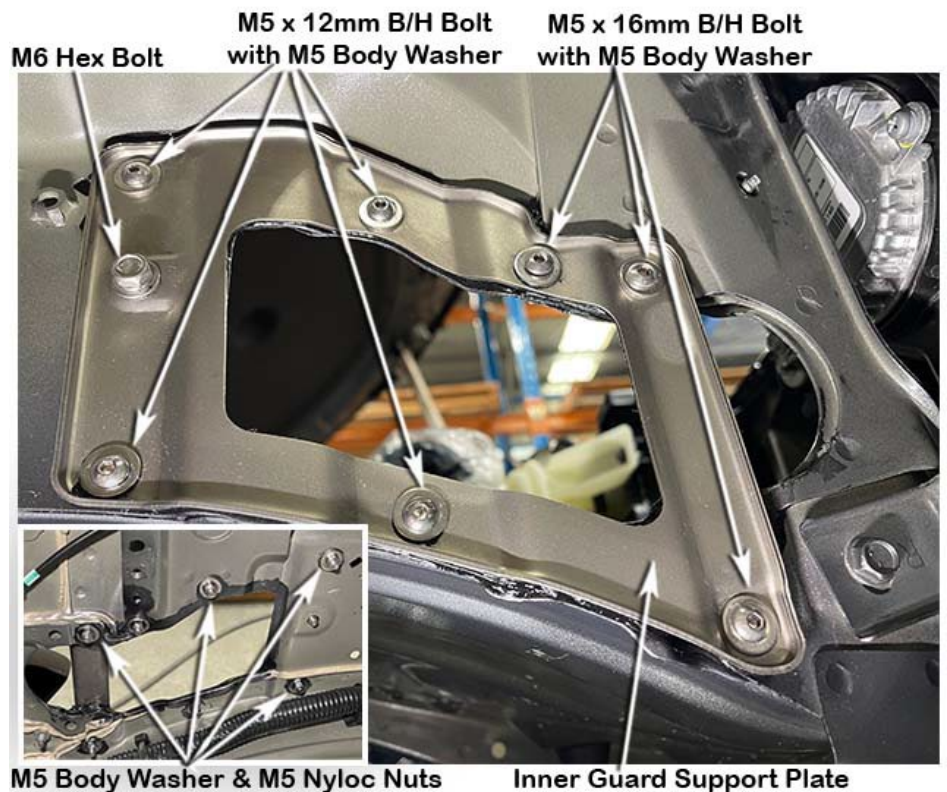

Measure and mark a line approximately 60mm down from the underside of the air cleaner mounting bracket.

Using a body saw, cut-off the lower section of the bracket as shown.

Measure and mark a hole position approximately 35mm down from the underside of the of the air cleaner mounting bracket as shown.

Drill the marked hole position to 5.0mm diameter.

Deburr and paint the hole and cut edge of the bracket to prevent rust.

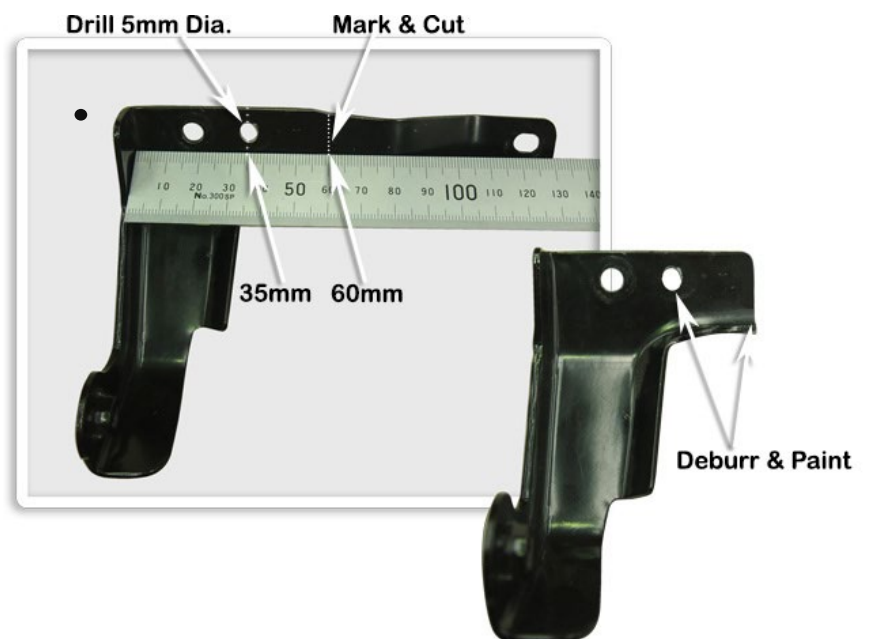

Install the air cleaner mounting bracket, fasten to the inner guard support bracket using the standard M6 mounting bolt.

Using a 5.0mm drill bit, drill the new lower mounting hole through the air cleaner mounting bracket and inner guard support bracket.

Remove the bracket and deburr and paint the 5.0mm hole.

Re-install the air cleaner mounting bracket and secure with the standard M6 bolt, install the 4.8 x 10mm pop rivet (item 37) through the bracket and inner guard support bracket, using the pop rivet gun secure the pop rivet.

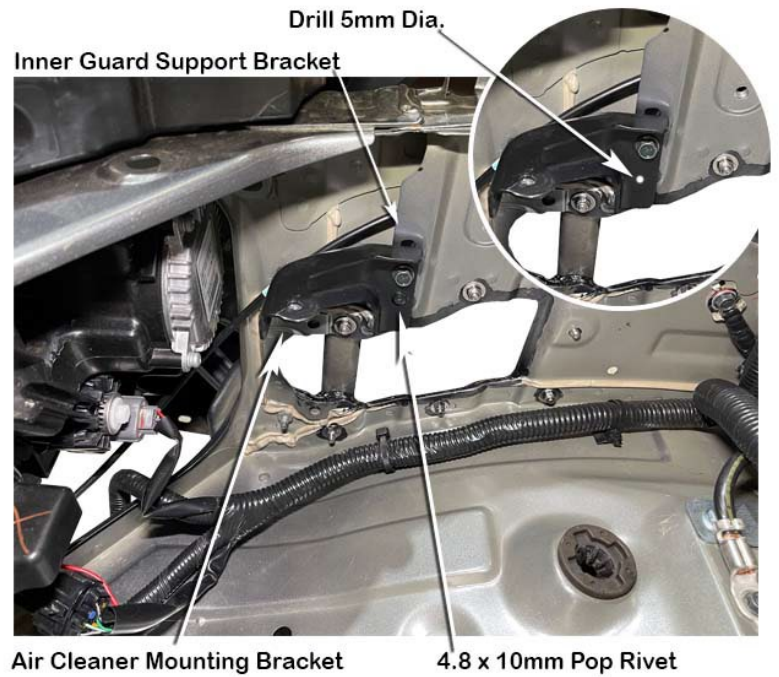

Assemble the ECU module to ECU relocation bracket (item 24) with four 6.0mm x 25mm hex bolts (item 28) and 6.0mm x 15mm body washers (item 29), install the bolts with washers installed through the bracket and ECU. Install the four standard ECU flange nuts and tighten the four nuts.

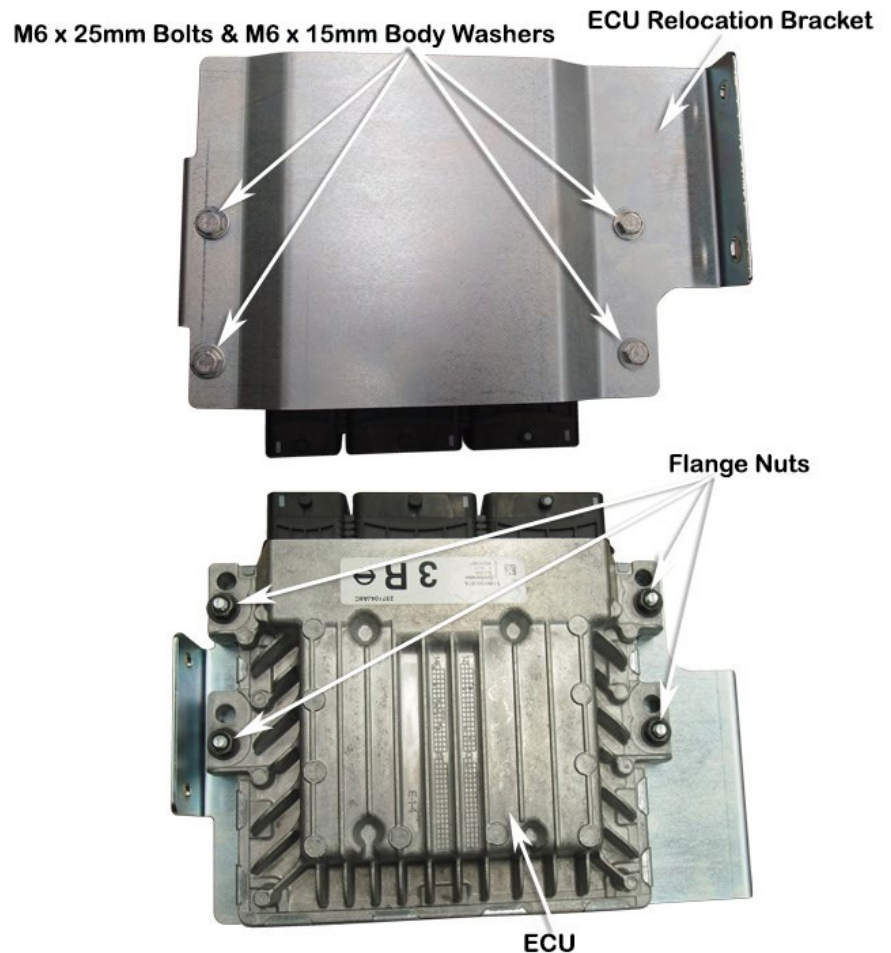

Remove and discard the main wiring harness rear cable tie as shown.

Remove and discard the small wiring loom cable tie as shown, re-route the small wiring loom so it runs under the brake booster.



Remove and Discard Cable Ties.

Remove the module from the inner guard panel shown, retain the standard bolt.

Install the ECU support bracket (item 25) to the inner guard panel, loosely Re-fit the module and ECU support bracket to the inner guard panel using the standard bolt.

ECU Support Bracket

Standard Bolt



Install two 6mm x 18mm body washers (item 31) over the two captive nuts in the wheel arch panel as shown, with the body washers in place install the ECU control module and ECU relocation bracket assembly to the vehicle. Install the two standard 6mm hex bolts previously removed in step one.

Secure the top of the ECU relocation bracket to ECU support bracket (item 25) with two 6mm x 14mm hex bolts (item 4)

Tighten all bolts securing the ECU relocation bracket and support bracket to the inner guard and wheel arch panel.

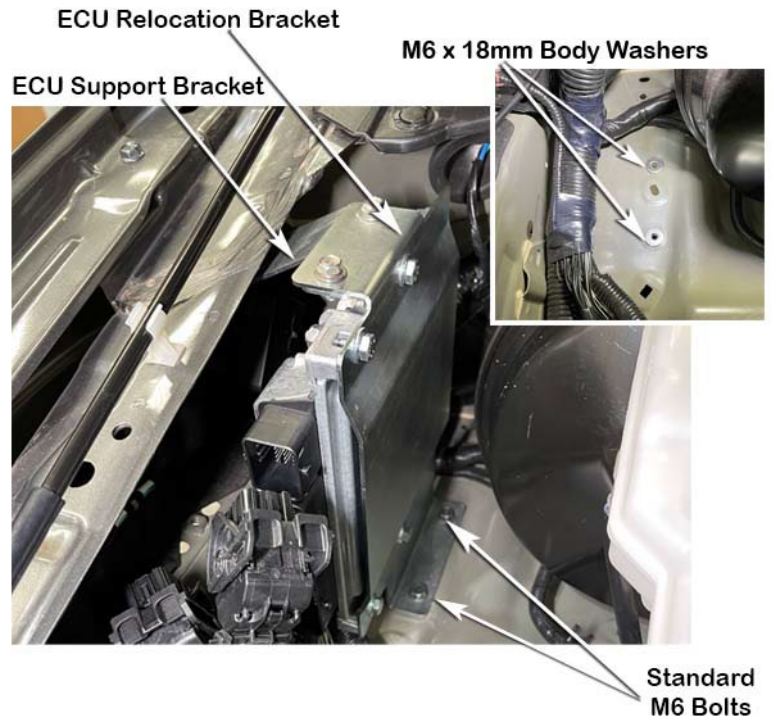

Re-route the ECU wiring harness and re-connect the three ECU wiring plugs to the ECU module.

ECU Plugs Reconnected.



Install a 6mm x 18mm body washer (item 31) onto each of the M6 studs in front of the brake booster.

Fit the relay box relocation bracket (item 26) over the two studs. Align the relocation bracket to the hole in the wheel arch panel, install a 6 x 16mm hex bolt (item 27) with a 6mm body washer (item 29) installed through the relocation bracket and wheel arch panel, secure with a 6mm body washer (item 29) and 6mm nyloc nut (item 30). Install a 6mm body washer (item 29) and 6mm nyloc nut (item 30) to each of the M6 studs and secure the bracket to the wheel arch panel.

Install the earth strap and secure with the standard M6 bolt removed in step 1.

Install the relay box mounting bracket to the two mounting studs on the relocation bracket, secure the bracket with the two 6mm flange nuts removed in step 1.

Re-fit the relay box to the relay box bracket. Secure the relay box to the bracket using the standard 6mm bolt removed from the bracket in step 1.

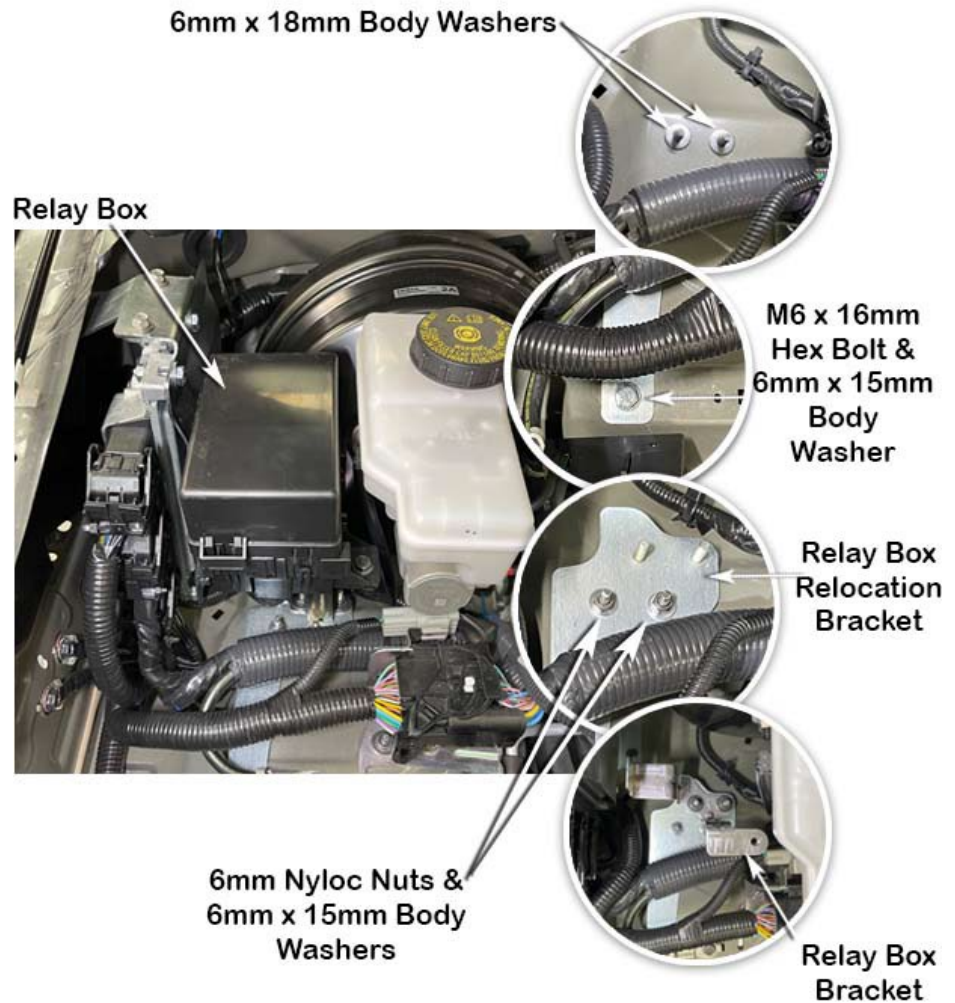

Remove and discard the air tube from the air cleaner base.

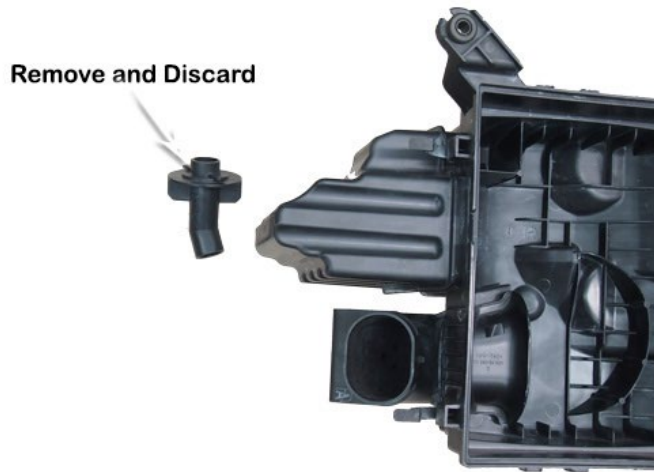

Align the air cleaner template to the air cleaner base.

Mark the two hole positions and the cut-out section onto the air cleaner base.



Using a body saw, remove the marked cut-out section of the air cleaner base.

Drill the marked hole positions to 4.5mm diameter.

Mark a line 25mm down from the underside edge of the air cleaner base

Using a grinder, remove the ribs from the outside of the air cleaner base below the marked line as shown.

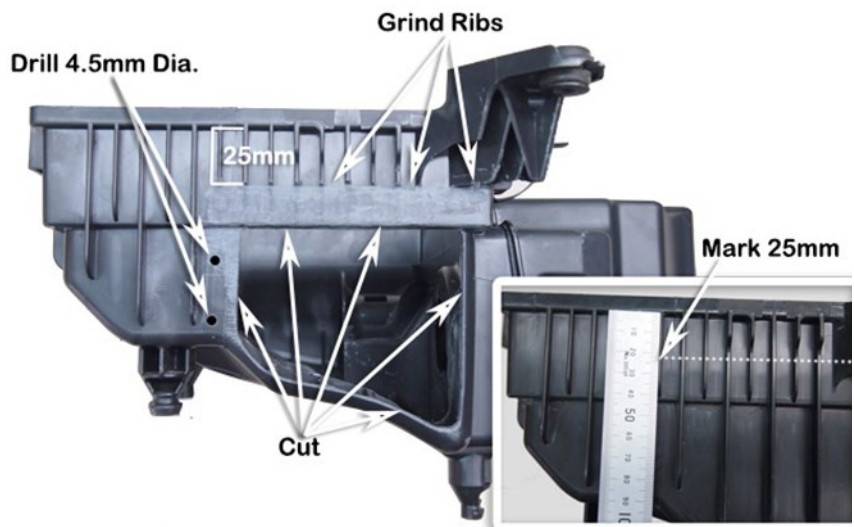

31

Using a body saw or die grinder remove the ribs as shown.

Using the body saw and die grinder, remove the panels as shown from the front right hand corner of the air cleaner base.

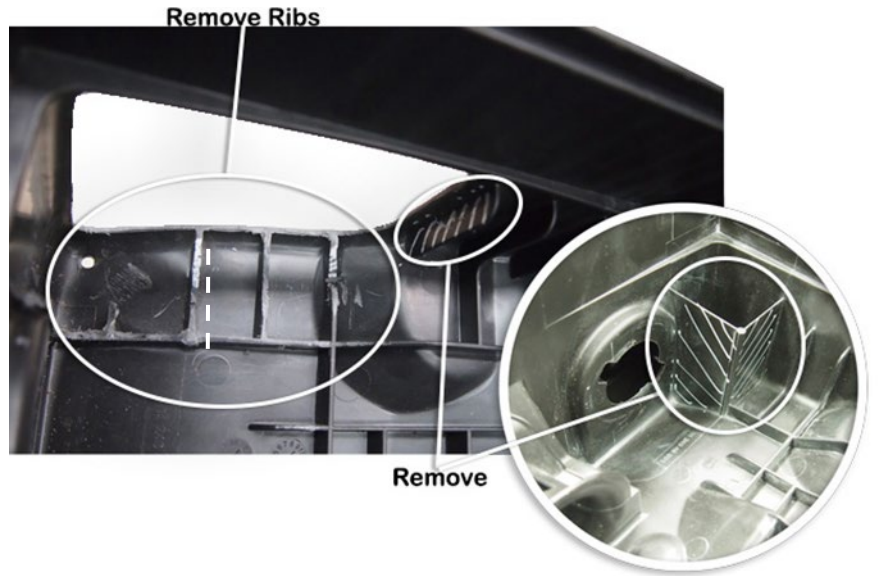

32

Mask along the edge of the air cleaner base.

Fit the air entry hose up to the air cleaner base and locate with two rivets through the 4.5mm holes drilled previously.

Mark the location of the remaining twelve holes using the air entry hose (item 10) as a template.

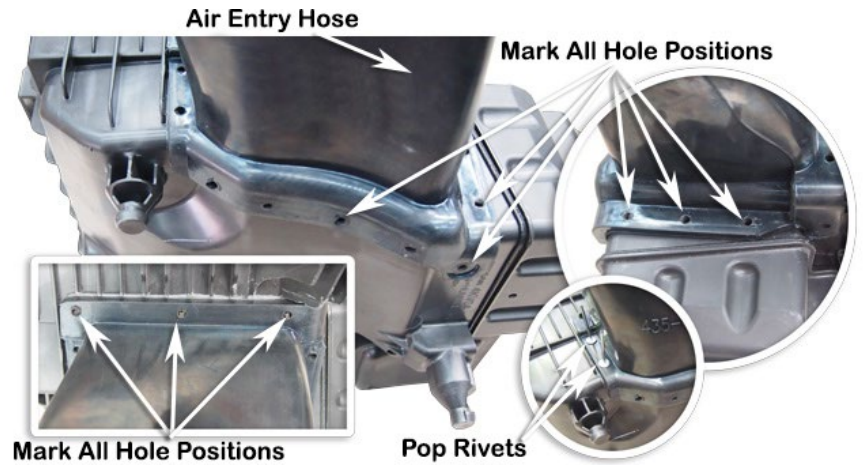

33

Remove the hose and drill the twelve marked hole positions with a 4.5mm drill bit.

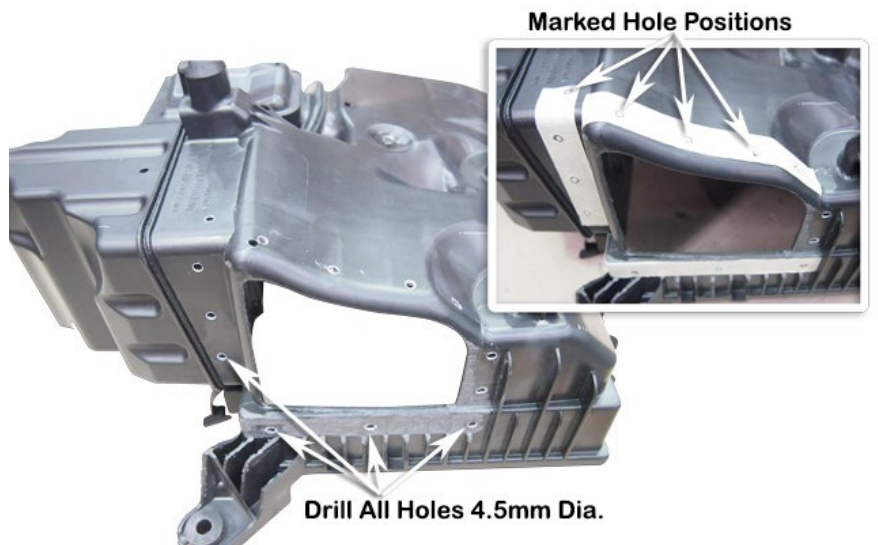

Apply sealant to the flange of the air entry hose.

Position the air entry hose onto the air cleaner base.

From the inside of the air cleaner base install six 4mm x 17mm pop rivets (item 18), install the upper and LH side clamp plates (items 14 and 16), install a 4mm body washer (item 20) onto the pop rivet at the top right hand corner as shown.

From the underside of the air cleaner base install the lower clamp plate (item 17) and install three 4mm x 17mm pop rivets (item 18), install a 4mm body washer (item 20) onto a 4mm x 17mm pop rivet (item 18) and install the pop rivet with body washer installed through the air entry hose and air cleaner base. Install a 4mm body washers (item 20) over the four lower rivets on the inside of the air cleaner base.

Install the RH side clamp plate (item 15) with three 4mm x 20mm splade pop rivets (item 19), install a 4mm body washer (item 20) onto a 4mm x 20mm splade pop rivet (item 19) and install the pop rivet with body washer installed through the lower air entry hose mounting hole.

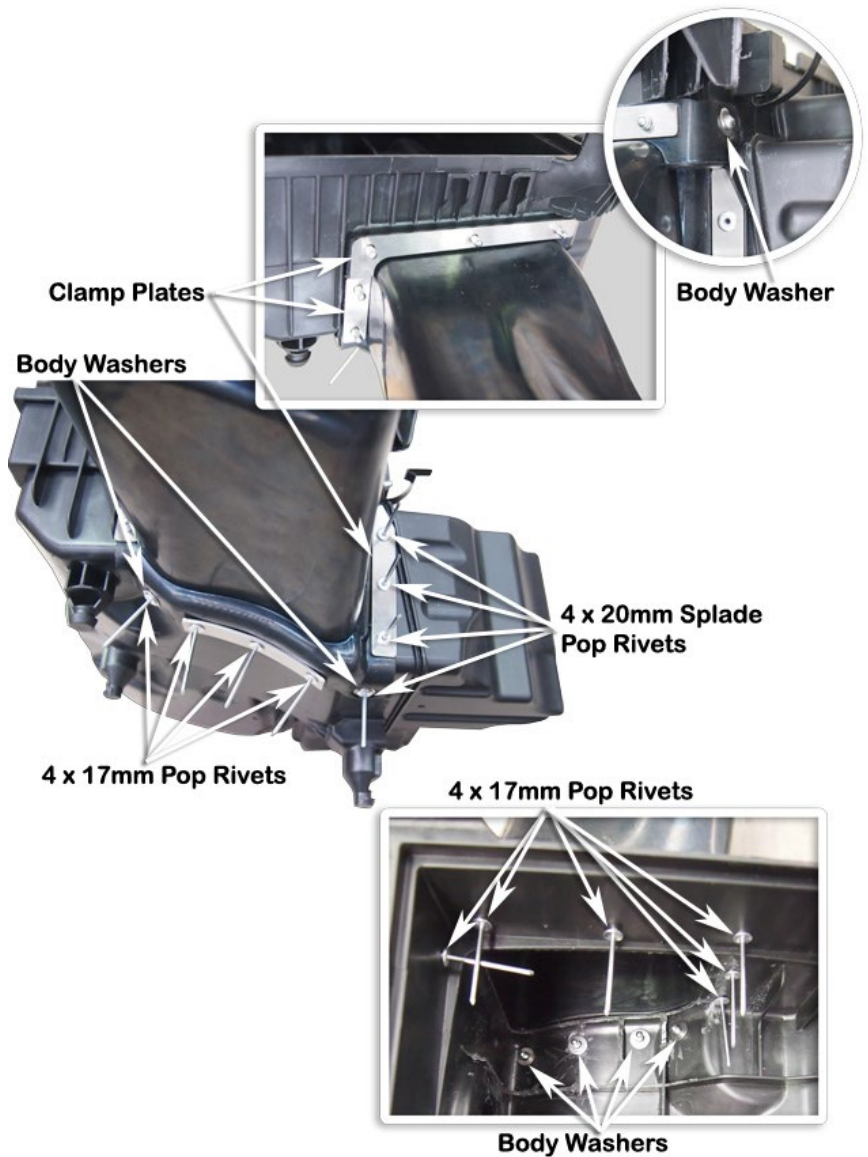

With all pop rivets, clamp plates and body washers in place, secure all pop rivets using a pop rivet gun. Clean-up any excess sealant to ensure a neat finish.

Install the air inlet blank-off cap (item 21) over the standard air intake hole, install a 50/70mm hose clamp (item 22) and tighten the hose clamp.

**Note the orientation of the hose clamp.**



**INSTALLER OPTION :**

The air cleaner housing base contains four drain holes as shown. The drain holes can permit water to enter the air intake.

Safari advises that the drain holes should be sealed to ensure a watertight installation.



Install the air cleaner base and hose assembly into the vehicle.

*Hint: squash the end of the hose whilst installing through the hole in the inner guard.*

Correctly install the air cleaner base into the three rubber mounting grommets and secure with the standard mounting bolt.

Loosely install the 70/90mm hose clamp (item 23) over the air intake hose (item 12) and position as shown.

**Note the orientation of the hose clamp.**

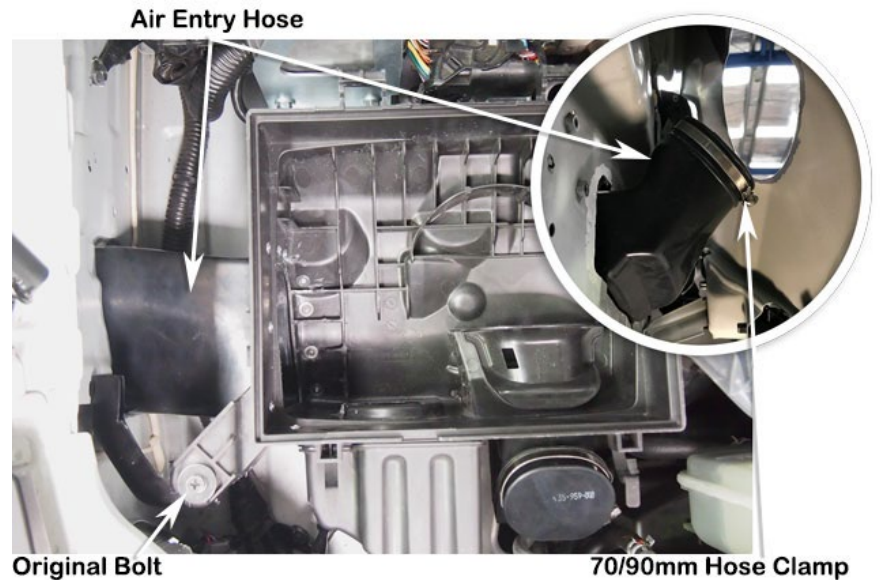

Apply a small amount of CRC lubricant to the air entry hose (item 12).

Carefully install the snorkel body (item 1) to the guard panel, guiding the snorkel body outlet snout into the air entry hose (item 12), align the snorkel body to the guard panel and upper mounting bracket.

When correctly aligned, fasten the snorkel body to the guard panel with body washers (item 9) and nyloc nuts (item 11), install the two M8 x 12mm hex bolts (item 8), spring washer (item 10) and body washers (item 9) into the two lower mounting inserts and tighten.

Fasten the snorkel body to the upper mounting bracket with hex bolts (item 4).

Ensure the air entry hose (item 12) is correctly installed onto the snorkel body outlet snout and tighten the 70/90mm hose clamp (item 23).

**Note the orientation of the hose clamp.**



40

Install the washer bottle assembly, ensuring it locates correctly into the rear mount bracket.

Install a 6 x 18mm body washer (item 31) onto each of the standard M6 mounting bolts, install the bolts with washers installed and secure the washer bottle into position.

Re-connect the two wiring plugs and the windscreen washer hose.

Re-install the filler neck and install the clip.

Refill washer bottle with washer fluid.



Standard M6 Bolts with  
M6 x18 Body Washers Installed

41

Install the black hose clamp (item 38) loosely over the base of the air ram assembly (item 2). Install the air ram assembly onto the snorkel body.

Align the air ram assembly and tighten the black hose clamp (item 38).



42

Reinstall the inner guard liner, mud flap, air cleaner element, air cleaner lid, reconnect mass sensor wiring plug, reconnect the negative battery terminal and any other items that may have been removed during the snorkel installation process. Road test vehicle.

43

**N.B:** It is the installer's responsibility to ensure that all connections are watertight.