



**4X4 ENGINEERING**

# SS987HFG

SAFARI V-SPEC SNORKEL  
FORD RANGER P703 / EVEREST U704  
2.3L 4cyl Turbo & 2.7L V6 Twin Turbo Petrol Engines



First Release 12/12/2024

## Parts List

ITEM	PART NO.	DESCRIPTION	QTY
1	682-133-000	BODY - SNORKEL (SS987HF)	1
2	000-135-800	3.5" AIR RAM ASSEMBLY	1
3	682-032-000	BRACKET - UPPER MOUNTING	1
4	000-002-100	BOLT - HEX - 6mm x 1.0 x 14mm (SEMS)	2
5	000-958-625	POP RIVET - 4.8mm x 10mm (Black Anodised)	3
6	683-435-000	GASKET - UPPER MOUNTING BRACKET (Nylon)	1
7	000-110	STUD - 8mm x 1.25 x 25mm - S/S	6
8	000-311-300	WASHER - BODY - 8mm x 30mm - S/S	6
9	000-205-300	NUT - NYLOC - 8mm x 1.25mm - S/S	6
10	682-024-200	HOSE - AIR ENTRY - (Flanged)	1
11	682-025-200	PLATE - HOSE MOUNTING (Inner)	1
12	682-025-250	PLATE - HOSE MOUNTING (Outer)	1
13	000-958-175	POP RIVET - 4.0mm x 17mm	4
14	000-094-300	BOLT - B/H CAP SCREW 4.0mm x 0.7 x 20mm - S/S	2
15	000-300-350	WASHER - BODY - 4.0mm x 12mm - S/S	4

16	000-223-300	NUT - NYLOC - 4.0mm x 0.7mm - S/S	2
17	000-909	CLAMP - HOSE - 80/100mm - S/S	1
18	682-959-200	PLUG - AIR INLET BLANK-OFF	1
19	000-987-365	CABLE TIE - 7.8mm x 365mm	1
20	000-987-178	CABLE TIE - 4.8mm x 178mm	2
21	000-987-100	CABLE TIE - 2.5mm x 100mm	4
22	000-914/B	CLAMP - HOSE - SIZE 56 (BLACK)	1
23	682-017-000	TEMPLATE - FENDER	1

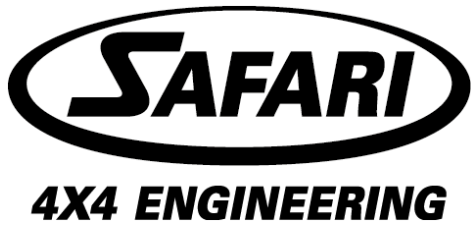

# SS987HFG

SAFARI V-SPEC SNORKEL  
FORD RANGER P703 / EVEREST U704  
2.3L 4cyl Turbo & 2.7L V6 TwinTurbo Petrol Engines

## Installation Guide

### Fitment to:

- Right Hand Side

### Fitting Time:

- 210min

### Special Tools:

- Body Saw (Reciprocating)
- Die Grinder
- Step Drill and Metric Drill Bits
- Sikaflex 227 Adhesive Sealant
- Pop Rivet Gun
- Allen Key Set (Metric)
- Files
- Masking Tape
- Loctite 243 (thread lock)
- Touch-up paint

**Prior to commencing the installation, it is the installer's responsibility to verify that all components and particularly the fender template (Item 23) are correct.**

1

Remove the following in accordance with the factory service manual:

- Air Cleaner Assembly
- RH Mud Flap
- RH Inner Guard Liner (Main Splash Guard Section)
- RH Front Wheel Arch Moulding
- RH Inner Guard Liner (Secondary Splash Guard Section)

**Hint:** Cover the air intake duct with a plastic bag or rag to prevent any foreign matter from entering the engines air intake and potentially causing turbocharger / engine damage.

**Caution:** Extreme care must be taken when removing the Front Wheel Arch Moulding, the wheel arch moulding clip mounts are very easily broken off.

**Hint:** To release the plastic clips use a 7mm or 8mm 1/4" drive socket and extension bar.

**Optional:** Remove the RH wheel arch moulding & RH Inner Guard Liner after the front fender snorkel hole modifications are complete. – See step 5

2

Remove and discard the two perforated sections from the fender template (item 23) as shown.

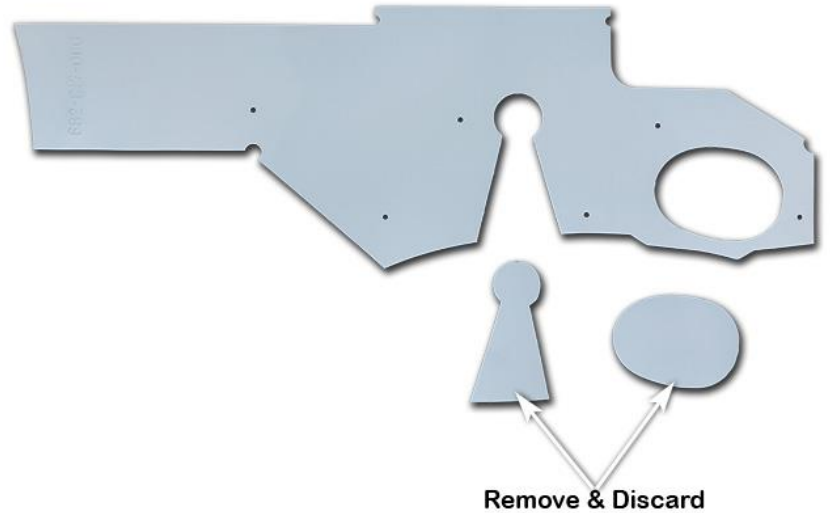

3

Align the fender template (Item 23) with the upper and rear edges of the right hand fender as shown.

Tape the template to the fender with masking tape, the template **must** follow the profile of the fender panel whilst being taped.

Mark all hole positions and the cut-out section with a felt tip pen.

Remove the fender template.

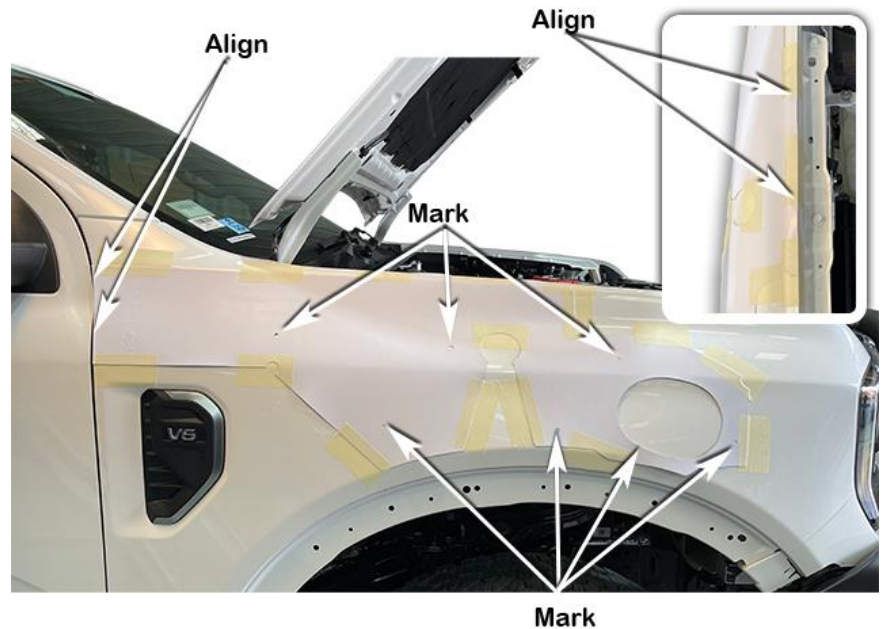

Drill a pilot hole for each of the marked hole positions.

Use a step drill to drill the six mounting holes to 16mm diameter.

Drill 1 or 2, 10mm diameter holes in the cut-out section for a start/stop point for the body saw, using the body saw cut the main hole in the fender as marked from the template cut-out in step 3, cutting on the outside of the marked cut line.

Thoroughly deburr and paint all holes and cut section of fender to prevent rust.

**Caution:** The drill bit length is extremely critical when drilling the pilot holes and 16mm diameter holes in the fender, the washer bottle assembly is mounted directly behind the area of the holes. **Do Not** use long drill bits.

**Hint:** Tape over the Fender vent and any other parts where metal swarf / filings can be trapped.

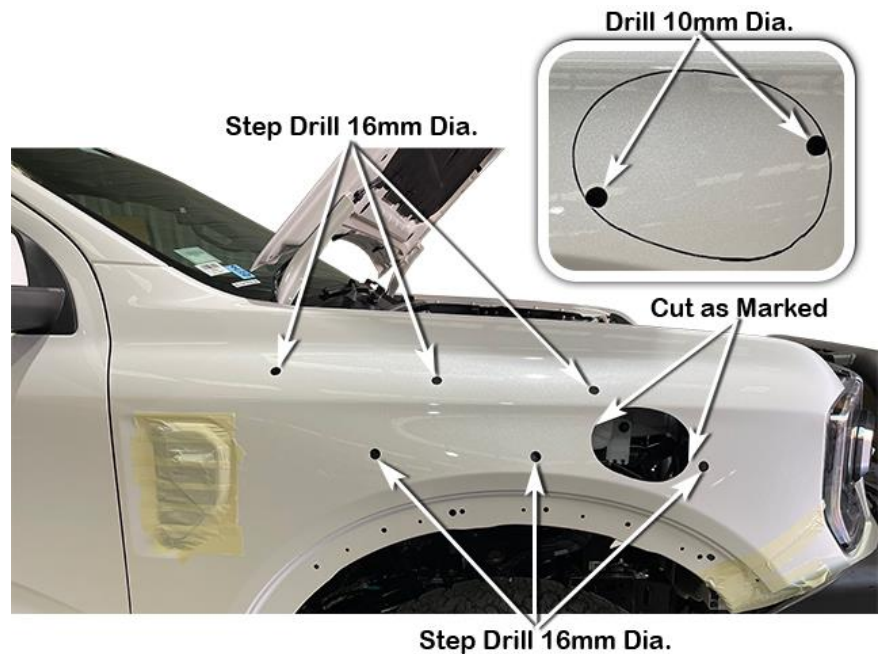

**OPTIONAL:** Remove the following in accordance with the factory service manual:

- RH Front Wheel Arch Moulding
- RH Inner Guard (Secondary Splash Guard Section)

**Note/Caution:** Extreme care must be taken when removing the Front Wheel Arch Moulding. Reach through the main hole in the fender and unclip as many of the plastic clips retaining the wheel arch moulding to the fender, carefully unclip the remaining plastic clips.

Install the upper mounting bracket (Item 3) to the snorkel body (Item 1) with hex bolts (Item 4).

Apply Loctite 243 to each of the stainless steel mounting studs (Item 7) and install the studs finger tight into the snorkel body (Item 1) mounting inserts as shown.

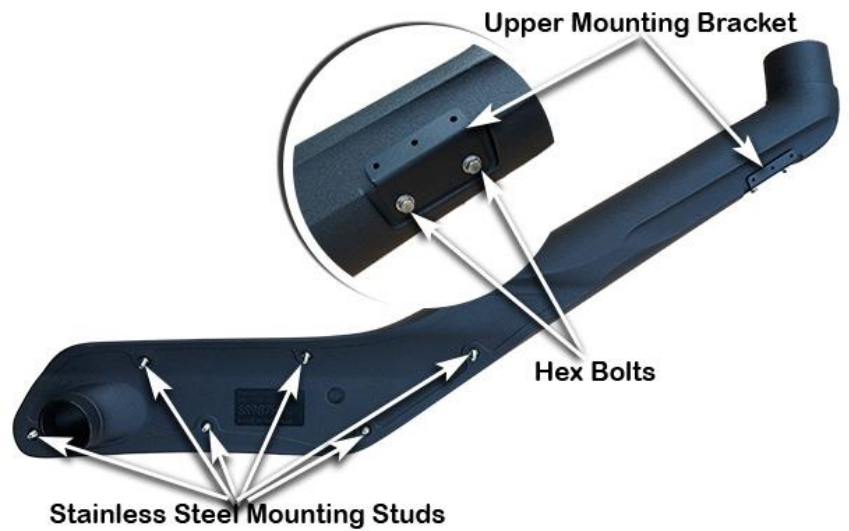

Place a strip of masking tape along the A-pillar panel.

Carefully install the snorkel body (Item 1) to the fender.

With the snorkel body correctly positioned, mark the outline of the upper mounting bracket (Item 3) onto the masking tape.

Distance from the marked line to front door edge should be approximately 10.0 - 11.0mm as shown.



Remove the snorkel body (Item 1) from the vehicle and remove the upper mounting bracket (Item 3) from the snorkel body.

Position the upper mounting bracket (Item 3) onto the A-pillar and align the bracket with the marked bracket outline.

Mark the three mounting hole positions with a felt tip pen.

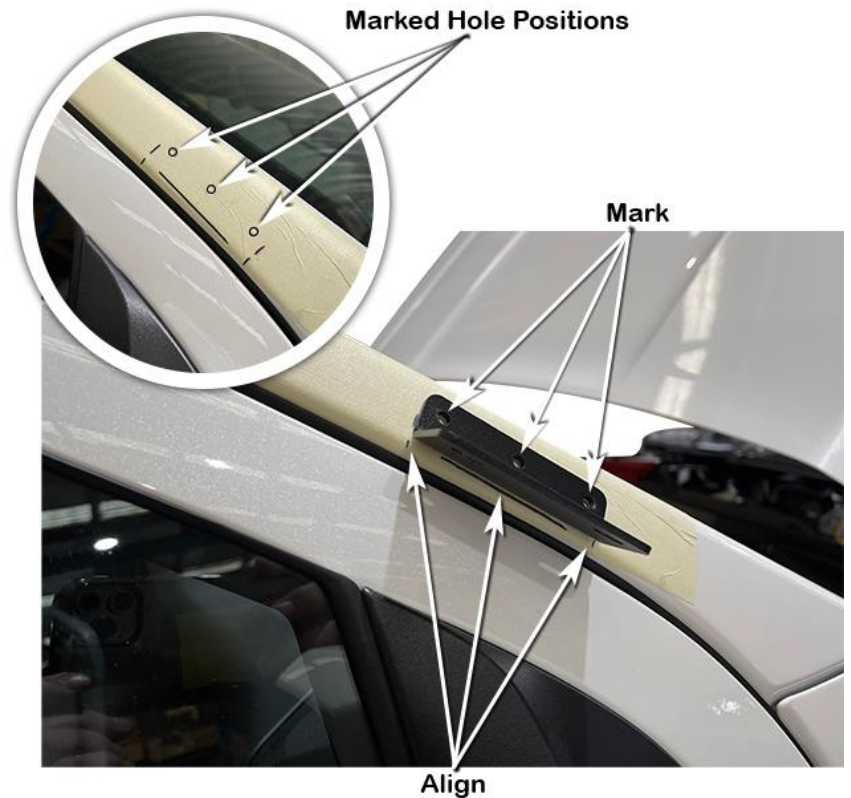

Drill a pilot hole at each of the three marked hole positions.

Drill each hole position to 5.0mm diameter with a 5.0mm drill bit.

Deburr and paint holes to prevent rust.

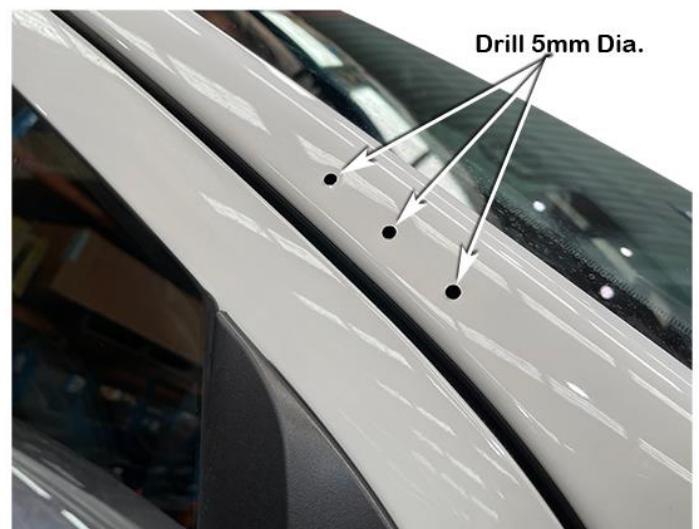

10

Install the nylon bracket gasket (item 6) to the upper mounting bracket (item 3) and install the upper mounting bracket and nylon bracket gasket onto the A-pillar.

Install the three pop rivets (item 5) through the bracket and gasket and into the three 5.0mm diameter holes in the A-pillar panel.

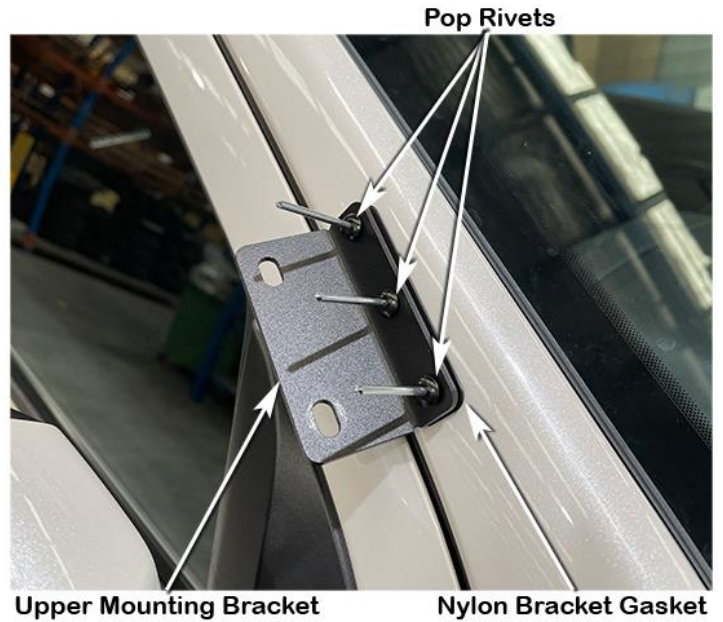

11

Using a pop rivet gun, secure the three pop rivets attaching the upper mounting bracket and nylon bracket gasket to the A-pillar panel.

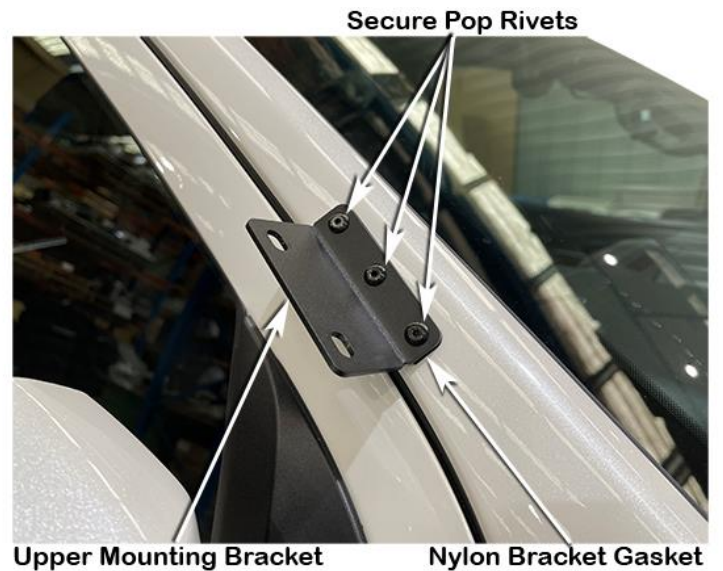

**INSTALLATION NOTE:**

Notice the distinction between the V6 and 4cyl air cleaner outlet duct assemblies.

Despite the difference in outlets, the modification to the air cleaner base and outlet sealing procedure remains the same.

***Note: The V6 Air Cleaner Outlet has been used in the following instruction steps.***

2.7L V6 Air Cleaner Assembly



2.3L 4cyl Air Cleaner Assembly



Remove and retain the standard air cleaner outlet assembly from air cleaner base as shown.

**Note: 2.7L V6 Air Cleaner Assembly shown.**

Air Cleaner Base



Loosen Bolts

Remove & Retain Outlet



Align the outer hose mounting plate (Item 12) to air cleaner base as shown, and tape into position.



Secure Outer Hose Mounting Plate

Mark the holes and inner edge of outer hose mounting plate (Item 12) onto the air cleaner base.

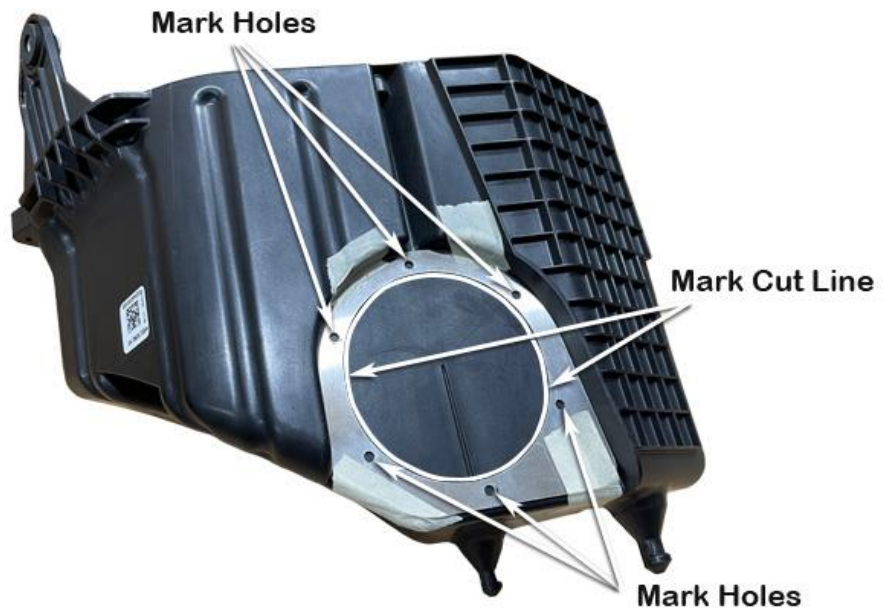

Remove outer hose mounting plate (Item 12).

Drill the six marked hole positions to 4.5mm Dia.

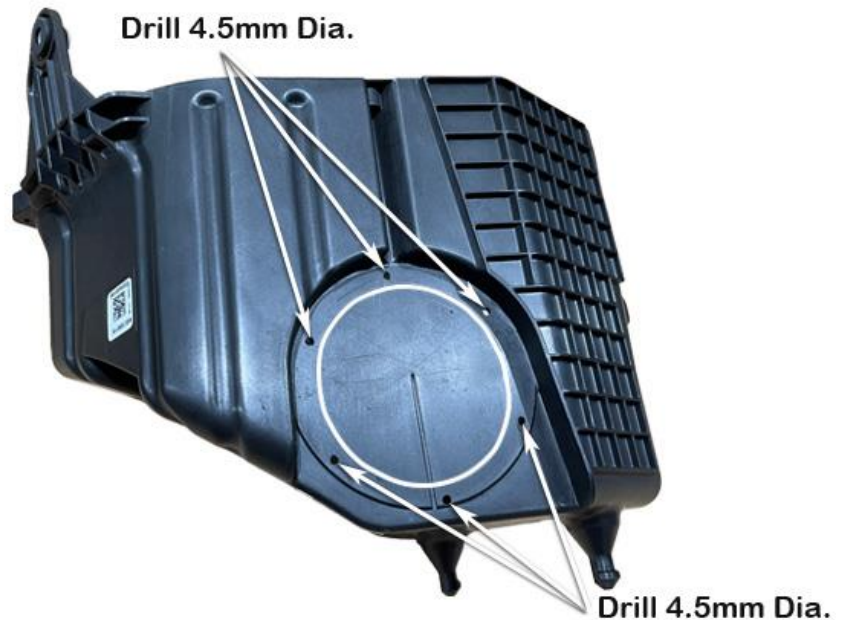

Drill a 10mm Dia. hole at the edge of the marked cut line to allow blade entry for cutting.

Cut out the marked section of the air cleaner base.

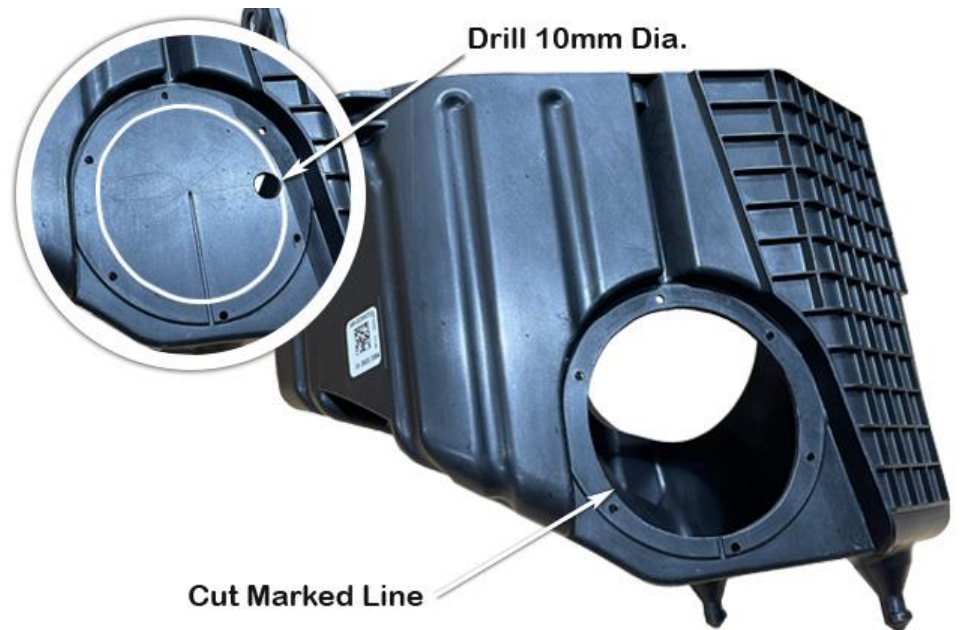

Install the outer hose mounting plate (Item 12) to the air entry hose (Item 10).

Slide the mounting plate (Item 12) along the body of the air entry hose (Item 10) up to the flange.

Take note of the plate's orientation.



Install the air entry hose (Item 10) into the new air cleaner base inlet.

Rotate and align the holes in the air entry hose flange with the 4.5mm drilled holes in the air cleaner base.

Apply Sikaflex 227 sealant to the internal mating surfaces of air entry hose flange (Item 10) and the new air cleaner base inlet.

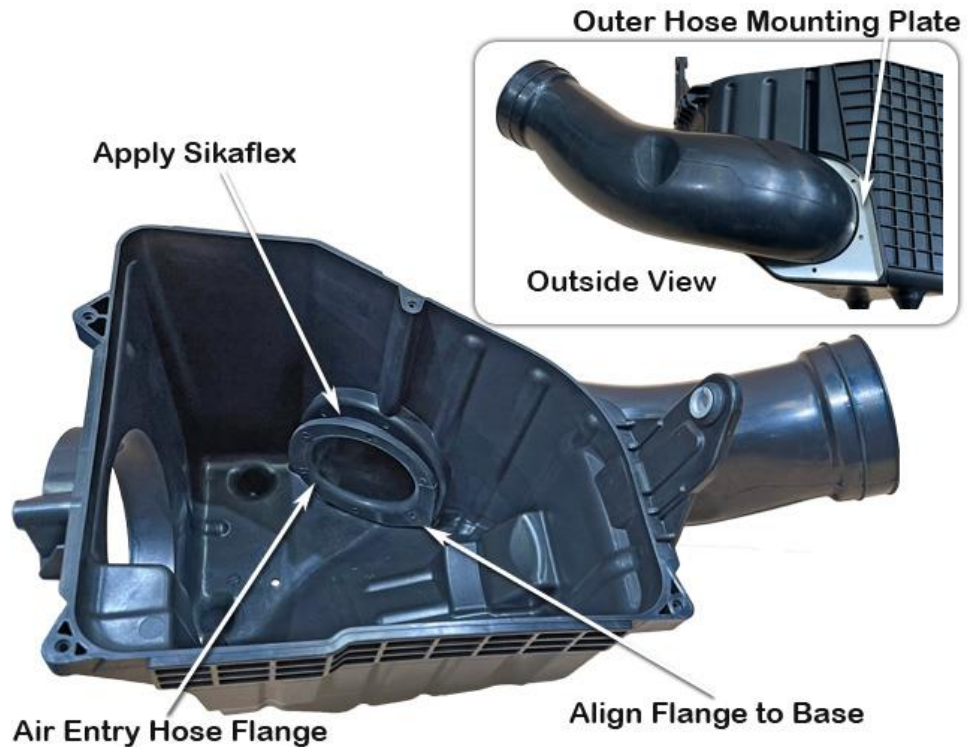

Install the inner hose mounting plate (Item 11) into position as shown.

Install the four 4mm pop rivets (Item 13) from the inside of the air cleaner base, into the positions shown.

Install the two 4 x 20mm B/H bolts (Item 14) & two 4 x 12mm body washers (Item 15), from inside the air cleaner base, into the positions shown.

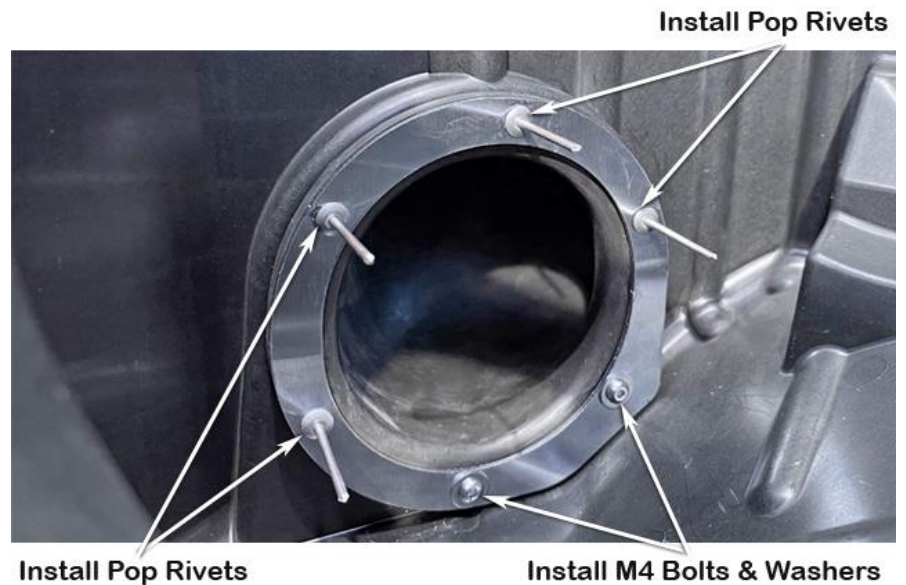

Install the remaining two 4 x 12mm body washers (Item 15) & 2x M4 Nyloc nuts (Item 16) to the 4 x 20mm B/H bolts (Item 14).

Tighten M4 Nyloc nuts (Item 16).

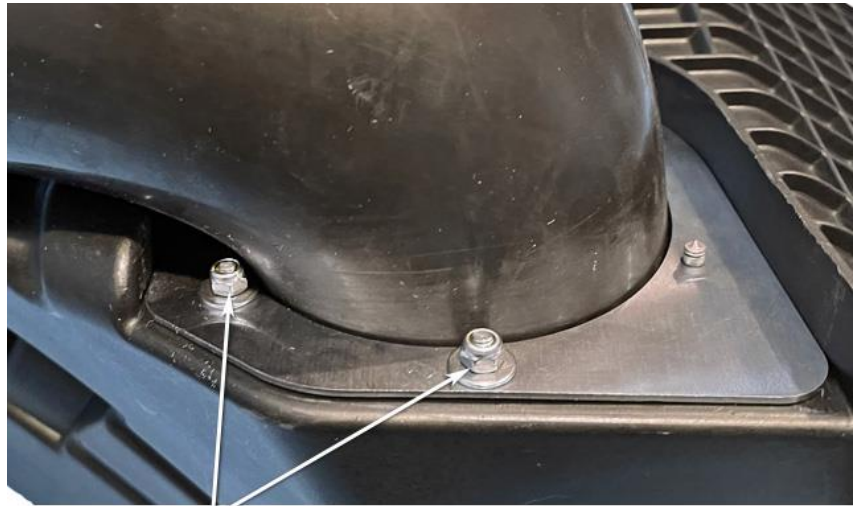

Install M4 Nyloc Nuts & Washers

Secure the four pop rivets (Item 13) from inside the air cleaner base.

Clean up any excess sealant to ensure a neat finish.

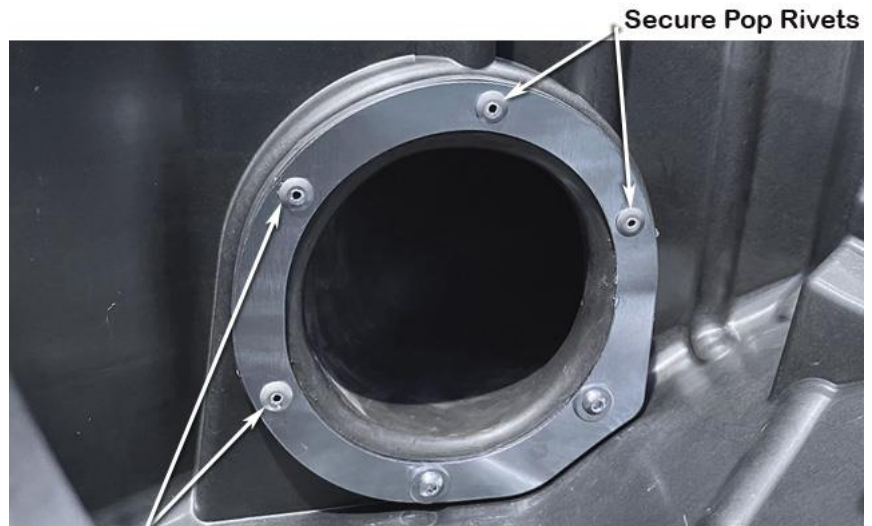

Secure Pop Rivets

Apply a liberal amount of Sikaflex 227 sealant to the standard air outlet in areas shown.

Clean excess sealant around air temperature sensor connector so as not to interfere when re-connecting the air temperature sensor connector plug.

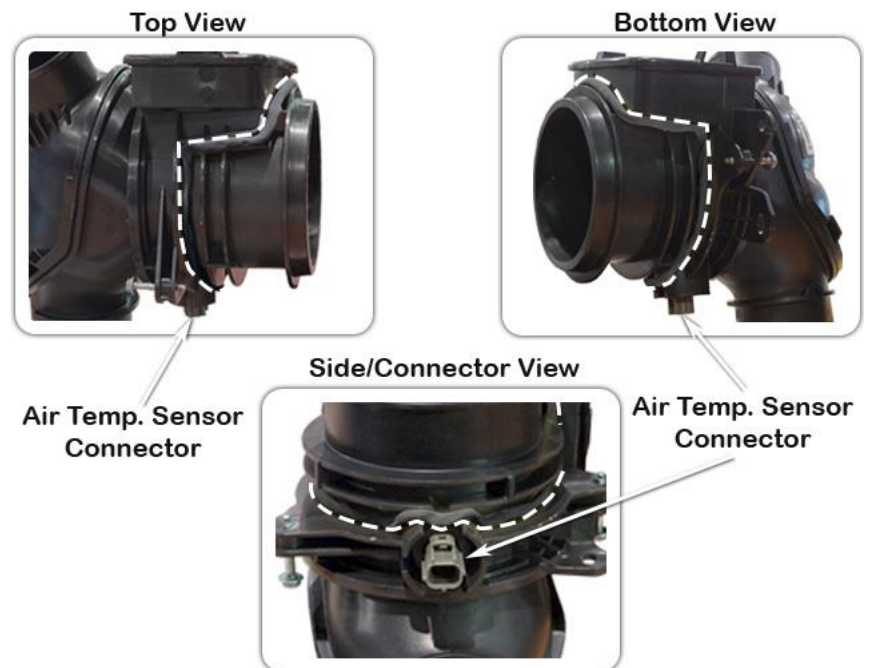

Install the standard air cleaner outlet back into the air cleaner base and secure with the original bolts.

Apply more Sikaflex 227 sealant externally to air cleaner base and the outlet if needed to ensure the air cleaner assembly is fully sealed.

Clean up any excess sealant to ensure a neat finish.

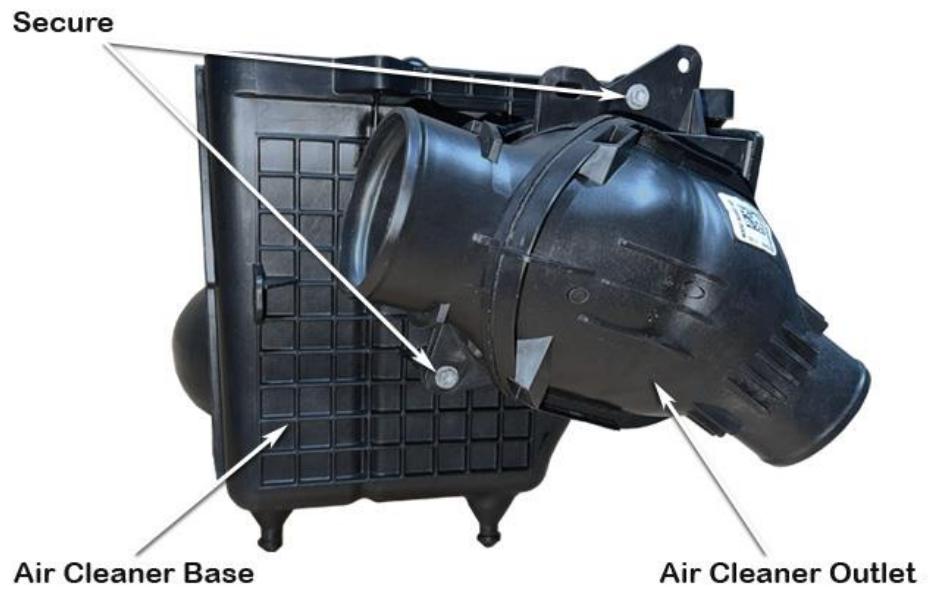

### **INSTALLER OPTION :**

The air cleaner base contains a drain hole as shown. The drain hole can permit water to enter the air intake.

Safari advises that the drain hole should be sealed to ensure a watertight installation.



Remove foam seal from the air cleaner lid where the standard air inlet was connected.

Clean area of any residual glue left behind.



Apply Sikaflex 227 around the outer flange of the Safari air inlet blank-off plug (Item 18).

Install the blank-off plug into the original air cleaner inlet hole.

Ensure the blank-off plug is fully inserted into air cleaner lid and blank-off plug clips are fully engaged.

Clean-up any excess sealant to ensure a neat finish.

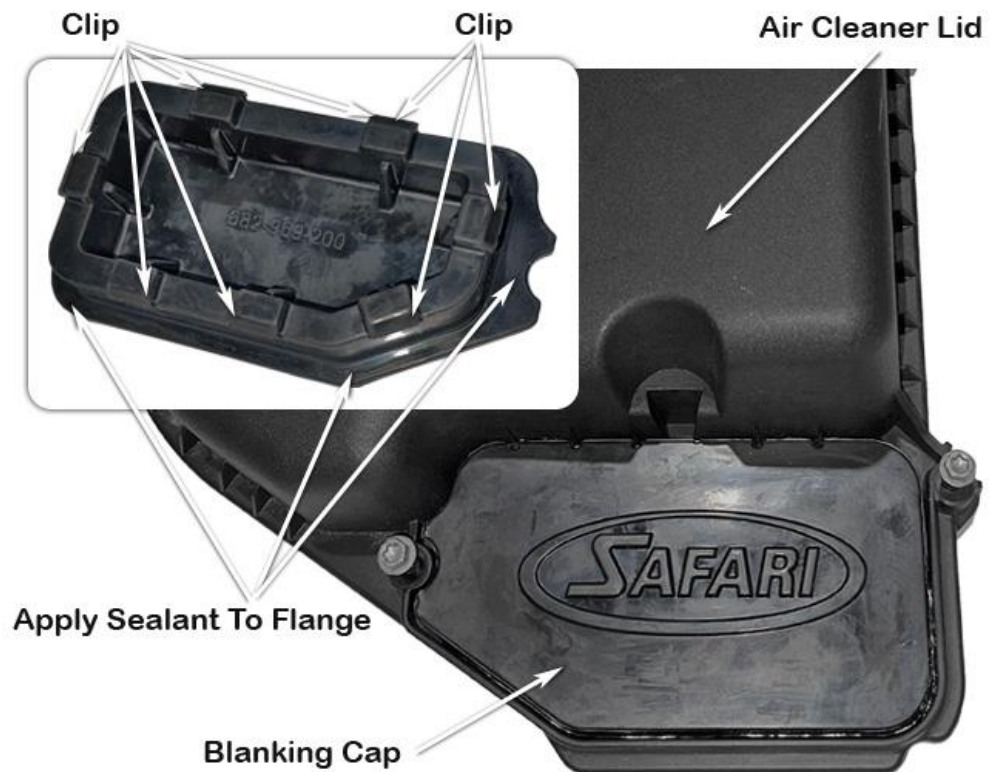

Cable tie the main loom to the vehicles top structure rail using the large cable tie (Item 19) as shown.

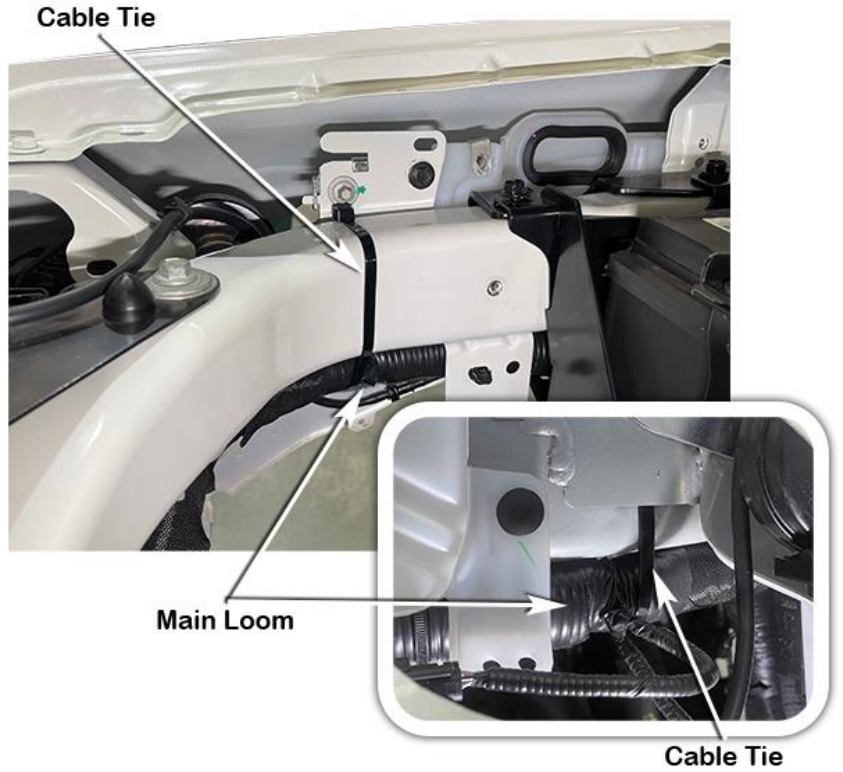

**Note: Depending on the model or specification of the vehicle, the horn and washer hose may or may not be present.**

Cable tie the washer hose and/or loom along the path shown using the remaining cable ties (Item's 20 & 21) where required, so they do not come into contact with the air entry hose (Item 10) when installed.





Install the air cleaner base with attached air entry hose (Item 10) back into the vehicle and fasten with the standard mounting bolt.

Loosely position 80/100mm hose clamp (Item 17) onto inlet of the air entry hose (Item 10).

**Note:** The orientation of the hose clamps.

80/100mm Hose Clamp



Air Entry Hose

Apply a small amount of lubricant to the inside of the air entry hose (Item 10).

Carefully install the snorkel body (Item 1) to the fender, guiding the snorkel body outlet into the air entry hose (Item 10), align the snorkel body to fender and upper mounting bracket.

When correctly aligned, fasten the snorkel body to the fender with the body washers (Item 8) and nyloc nuts (Item 9).

Fasten the snorkel body to the upper mounting bracket with the hex bolts (Item 4).

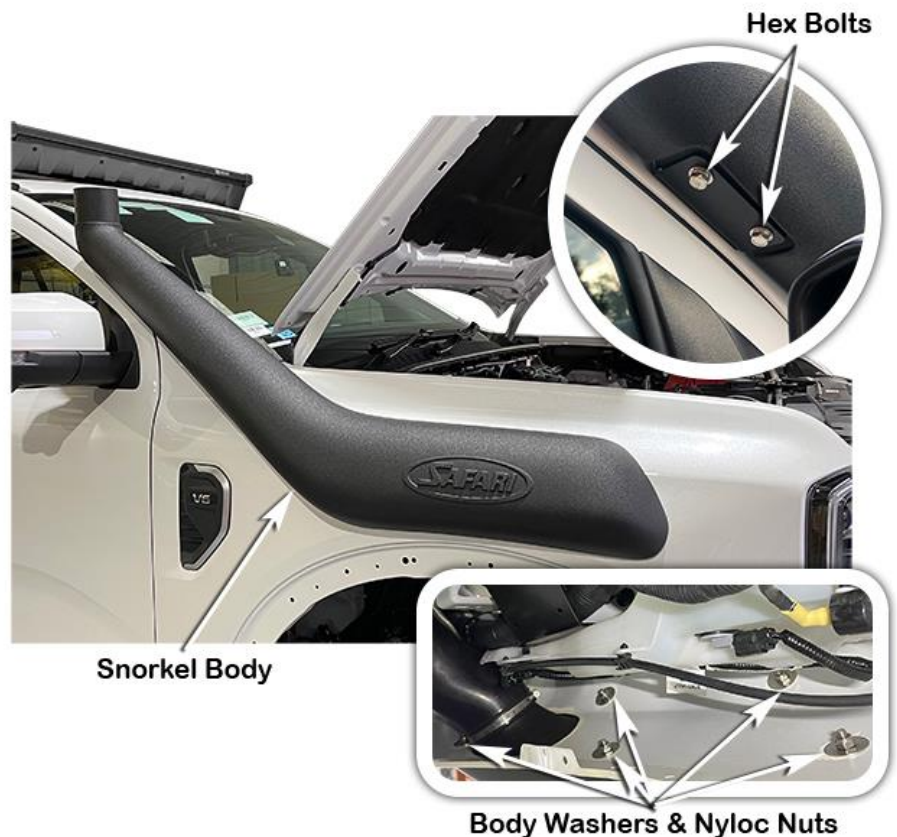

Snorkel Body

Body Washers & Nyloc Nuts

31

With the air entry hose correctly installed onto the snorkel body outlet snout, tighten the 80/100mm hose clamp (Item 17).

**Note: The orientation of the hose clamp.**

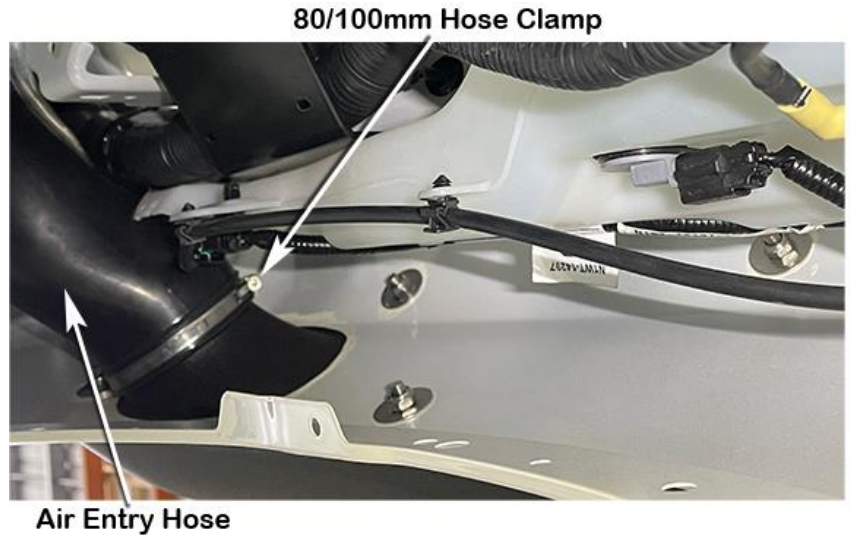

32

Loosely install the black hose clamp (Item 22) over the base of the air ram assembly (Item 2).

Install the air ram assembly onto the snorkel body.

Align the air ram assembly and tighten the black hose clamp (Item 22).



33

Re-install the RH Inner guard liner (Secondary Splash Guard Section), Front wheel arch moulding, RH Inner guard liner (Main Splash Guard Section), air cleaner element, air cleaner lid, reconnect sensor wiring and any other items that may have been removed during the snorkel installation process.

34

**N.B: It is the installer's responsibility to ensure that all connections are watertight.**