



SAFARI V-SPEC SNORKEL

SS75HF

04/02/03

ITEM	DESCRIPTION	QTY	PART NO
1	BODY - SNORKEL	1	330-133-000
2	3" AIR RAM ASSEMBLY	1	000-135-050
6	BRACKET - UPPER MOUNTING	1	330-032-000
3	STUD - S/S - 8mm x 1.25 x 25mm - O/L	4	000-110
4	WASHER BODY - 8mm x 30mm	4	000-311
5	NUT - NYLOC - 8mm x 1.25	4	000-205
7	BOLT - HEX- 6mm x 1.0 x 14mm	2	000-002-100
9	CLIP - BODY - PLASTIC	3	000-960
10	SCREW - S/T - 4.2 x 13mm	3	000-951
11	ADAPTOR - AIR CLEANER	1	330-023-000
12	"O" RING - 8mm SECTION x 290mm	1	000-470-029
13	POP RIVET - 4mm x 12mm	6	000-958
15	TEMPLATE	1	330-017-200
16	HOSE CLAMP - SIZE 48 (BLACK)	1	000-918/B

WARNING!!

IT IS AN INSTALLER
RESPONSIBILITY TO VERIFY
ALL COMPONENTS, AND
PARTICULARLY THE
TEMPLATE ARE CORRECT,
BEFORE STARTING ANY PART
OF THE SNORKEL
INSTALLATION.

(CHECK TEMPLATE AGAINST
SNORKEL BODY)



SAFARI V-SPEC SNORKEL

SS75HF

To Suit: TOYOTA LANDCRUISER HJ/FJ 75

2H DIESEL (4.0L)
3F PETROL (3.4L)

Fitment to: Right hand side
Fitting time: Approximately 120 minutes
Special Tools: 89mm holesaw
Air hacksaw (Uigsaw)
Pop rivet gun

Instructions:

1. Remove the air cleaner assembly and plastic air ducting from the engine bay. The Landcruiser badge will need to be removed from the right hand guard.
2. Tape the template in position on the vehicle (refer to the drawing) and mark all the hole positions using a felt pen. Remove the template.
3. Drill a 4mm pilot hole for each of the holes. Open out the 4 mounting holes to 16mm using a step drill. Using an 89mm holesaw, cut the main hole. The drill should be held at 90° to the panel while cutting this hole. After drilling/cutting, deburr each hole to leave a clean edge.

NEW ZEALAND INSTALLATIONS ONLY :

Safari have developed 2 methods of Snorkel A pillar attachment, for the conventional method please proceed with the current document alternatively please see the link below for further instructions.

www.safari4x4.co.nz/apillarmounting

4. Screw the stainless steel studs into the inserts in the back of the snorkel. Fasten the upper mounting bracket to the snorkel using 2, 6mm bolts and washers. Locate the snorkel on the vehicle and mark the upper mounting holes on the "A" pillar using a felt pen. Remove the snorkel and drill the mounting holes to 8mm.
 5. Paint all holes to prevent rust. Insert the plastic body clips into the upper mounting holes. Position the snorkel on the vehicle and secure using appropriate hardware.
 6. Remove the air cleaner snout from the air cleaner by drilling out the spot welds. A sharp chisel will be needed to carefully separate the snout from the main air cleaner body. Remove the deflector from inside the air cleaner also. Slide the adapter casting onto the snorkel snout. Place the air cleaner in position and mark the casting location on the air cleaner body. Remove the air cleaner and casting from the car. Locate the casting on the air cleaner body and via the adapter snout, mark the internal hole location. Remove the adapter and using an air hacksaw, cut the new inlet hole to match the casting. Rivet the casting into position on the air cleaner body and seal the joint with silicone.
 7. Place a bead of silicone around the adapter snout and refit the air cleaner to the vehicle.
 8. Sit the air ram on top of the snorkel and secure it using the clamp supplied.
- * A small bead of silicone may be placed around the top and front edges of the snorkel to seal it against the vehicle.

SS-75 H/F 2H DIESEL - 3F PETROL ENGINE Pre-April '90

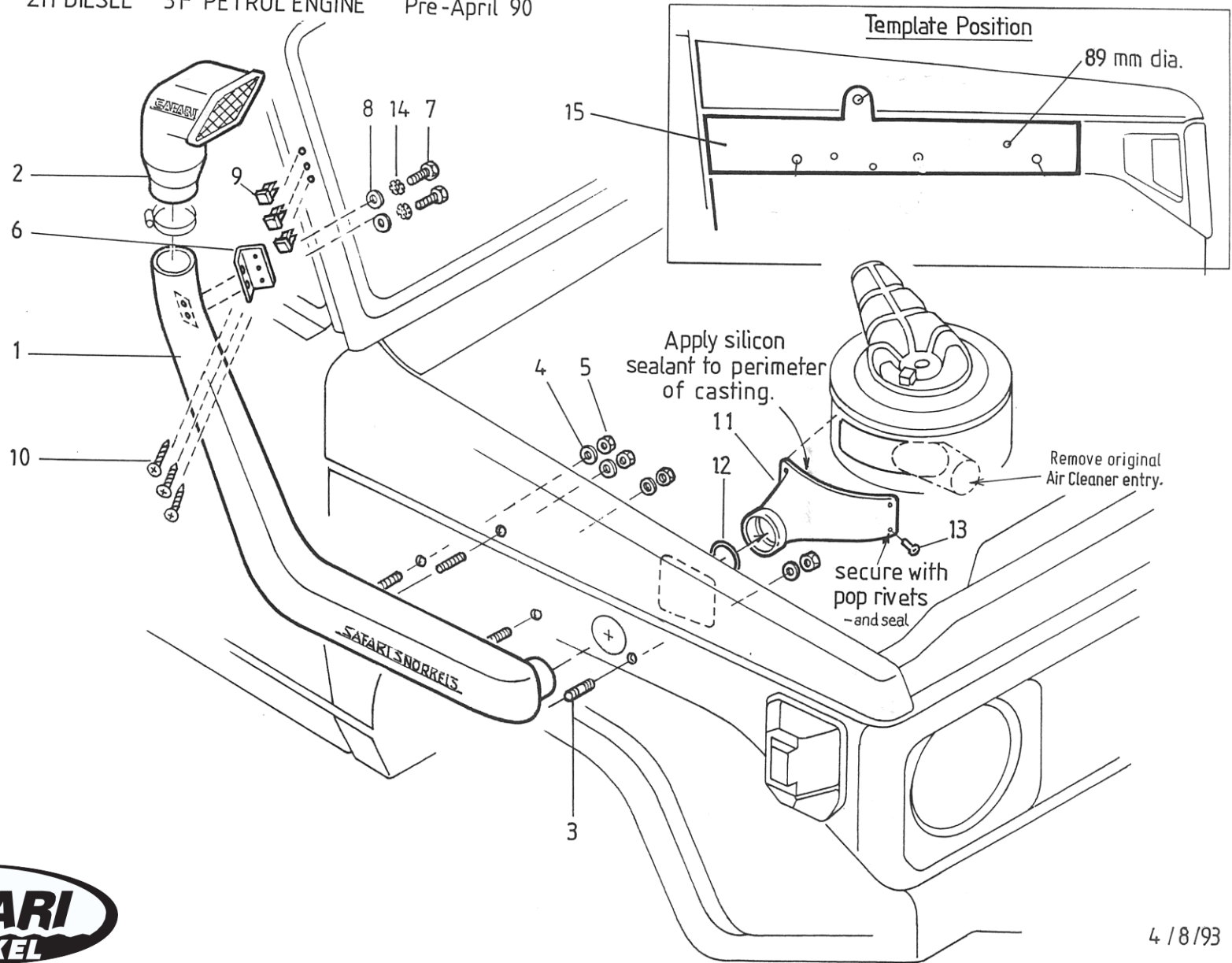

4 / 8 / 93