



SS177HP

SAFARI ARMAX SNORKEL

Suits: ISUZU D-Max RG01 TFR/S MY21 (All Models)
& ISUZU MU-X RJ01 UCR/S MY22 (All Models)
3.0L Turbo Diesel (4JJ3-TCX Engine)



01/11/2022

Parts List

ITEM	PART NO.	DESCRIPTION	QTY
1	741-133-600	BODY - SNORKEL (SS177HP)	1
2	000-135-980	ARMAX AIR RAM ASSEMBLY	1
3	741-032-600	BRACKET - UPPER MOUNTING	1
4	000-002-100	BOLT - HEX - 6mm x 1.0 x 14mm (SEMS)	2
5	000-951-480	SCREW - S/T - 4.2mm x 13mm - (Black)	7
6	000-960	INSERT - PLASTIC	3
7	000-110	STUD - 8mm x 1.25 x 25mm - S/S	6
8	000-311-300	WASHER - BODY - 8mm x 30mm - S/S	6
9	000-205-300	NUT - NYLOC - 8mm x 1.25mm - S/S	6
10	741-024-600	HOSE - AIR ENTRY (Flanged)	1
11	741-025-025	PLATE - HOSE SUPPORT	4
12	741-025-600	PLATE - HOSE SUPPORT (UPPER)	1
13	741-025-625	PLATE - HOSE SUPPORT (LOWER)	1
14	000-958-150	POP RIVET - 4.0mm x 13mm	16
15	000-300-350	WASHER - BODY - 4mm x 11mm - S/S	2

16	741-217-600	TEMPLATE - AIR CLEANER (MAIN)	1
17	741-217-700	TEMPLATE - AIR CLEANER (FRONT)	1
18	741-959-000	CAP - BLANK-OFF (Moulded)	1
19	000-908	CLAMP - HOSE - 70/90mm	1
20	000-1911	CLAMP - HOSE - 100/120mm	1
21	741-016-600	RUBBER - FENDER INFILL (NON FACTORY FLARE MODELS ONLY)	1
22	741-017-700	TEMPLATE - INNER GUARD CUT-OUT	1
23	741-017-600	TEMPLATE - GUARD PANEL (SS177HP)	1



ARMAX

SS177HP

SAFARI ARMAX SNORKEL

Suits: ISUZU D-Max RG01 TFR/S MY21 (All Models)
& ISUZU MU-X RJ01 UCR/S MY22 (All Models)
3.0L Turbo Diesel (4JJ3-TCX Engine)

Installation Guide

Fitment to:

- Right Hand Side

Fitting Time:

- 240min

Special Tools:

- Body Saw (Reciprocating)
- Step Drill
- 2.0mm & 4.5mm Drill Bits
- Files
- Loctite 243 (thread lock)
- Touch-up paint
- Sikaflex 227 Adhesive Sealant
- Masking Tape

Prior to commencing the installation, it is the installer's responsibility to verify that all components and particularly the template (Item 22 & 23) are correct.

1

Remove and discard the standard Air intake duct.



Remove & Discard

2

Remove the following in accordance with the factory service manual:

- RHS Mud Flap
- RHS Guard Liner
- Air Cleaner Assembly

3

Remove and discard the two perforated sections of the guard panel template (item 23) as shown.

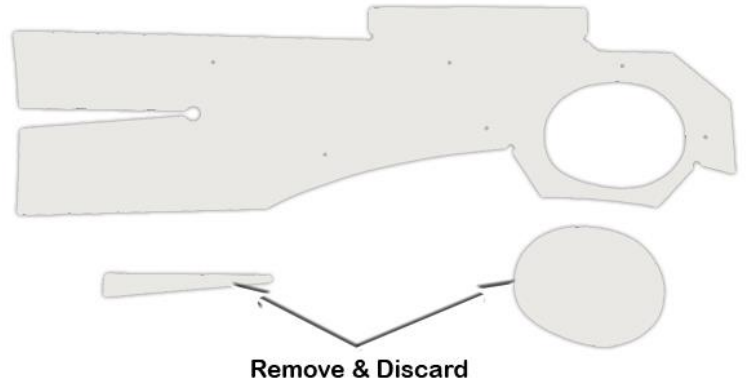

Non-Factory Flared Vehicle Models Only:

See Steps: 4, 5 & 6

4

Align the guard panel template (Item 23) with the upper corner, upper and rear edges of the RHS guard panel as shown.

Tape the template to the guard panel with masking tape.

Mark all hole positions and the main hole cut-out with a felt tip pen.

Remove the template.

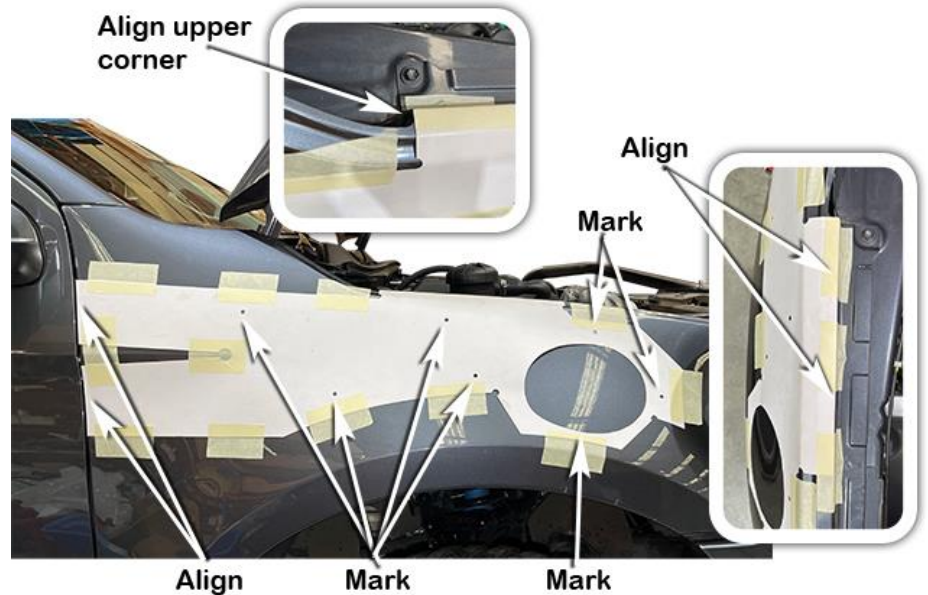

5

Drill a pilot hole for each of the marked hole positions.

Use a step drill to drill the six mounting holes to 16mm diameter.

Drill 1 or 2, 10mm diameter holes in the cut-out section for a start/stop point for the body saw, using the body saw cut the main hole in the guard panel, cutting on the **marked line** as marked from the template cut-out in step 4.

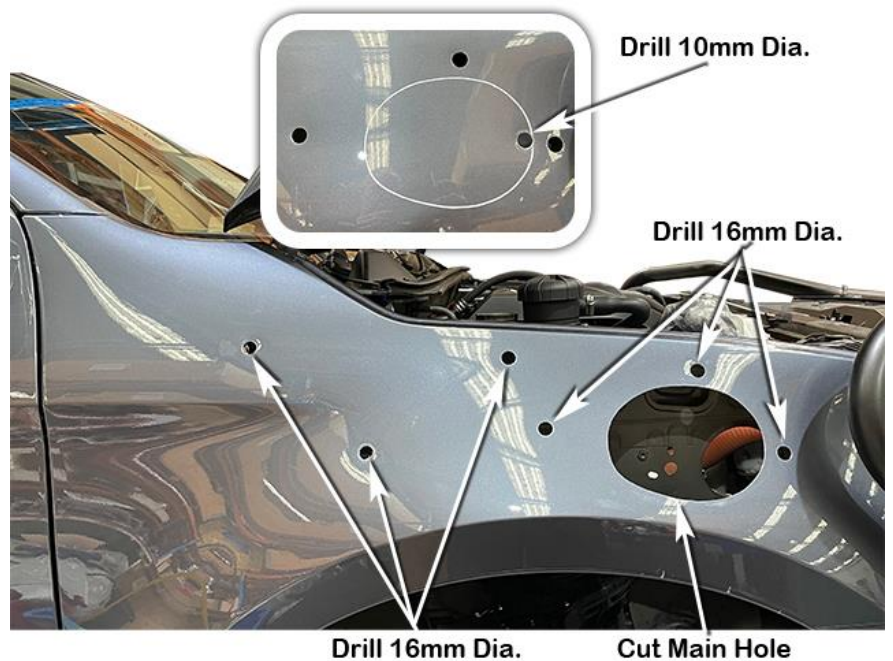

Using a sharp knife or chisel remove the sound deadening pad from behind the rear most 16mm diameter mounting hole (if required).

Ensure to remove enough of the pad from around the 16mm hole to allow the 8mm body washer (item 8) to sit flat against panel.

Deburr and paint the main hole cut-out and the six 16mm diameter holes.

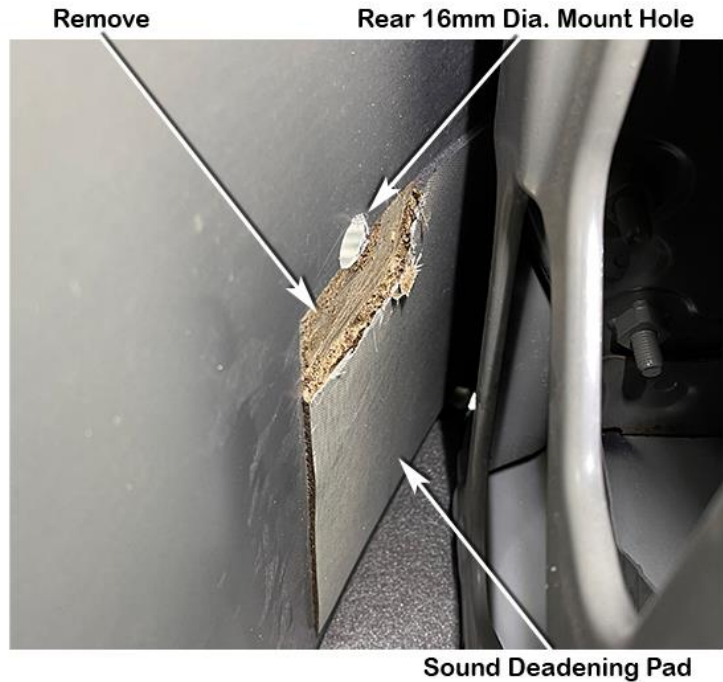

Factory Fender Flare X-Terrain Vehicle Models Only:

See Steps 7 – 10.

Align the guard panel template (Item 23) with the upper corner, upper and rear edges of the RHS guard panel as shown.

The template should follow the top edge of the flare rubber.

Tape the template to the guard panel and flare with masking tape.

Mark all hole positions and the main hole cut-out with a felt tip pen.

Remove the template.

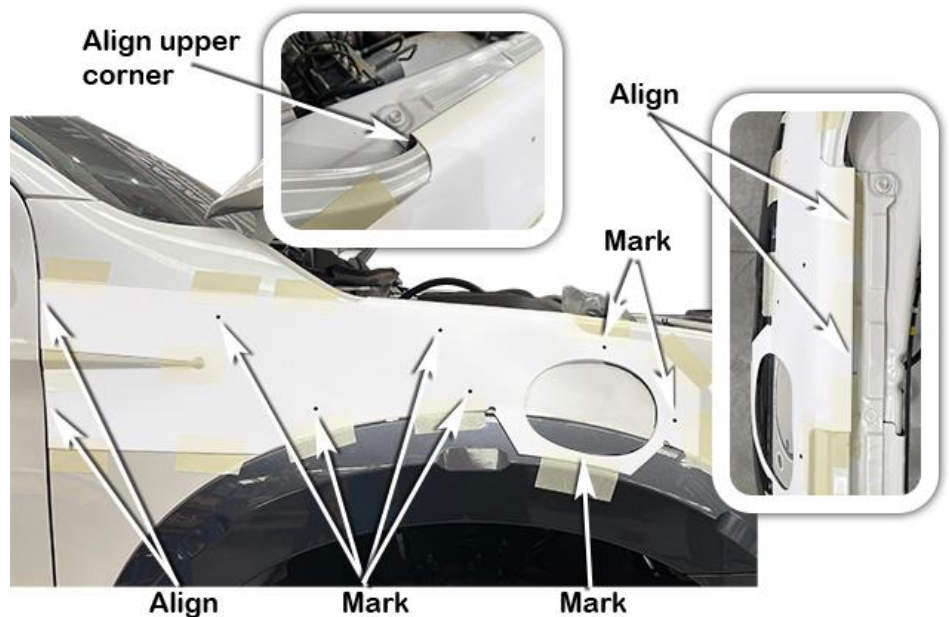

Drill a pilot hole for each of the marked hole positions.

Use a step drill to drill the six mounting holes to 16mm diameter.

Drill 1 or 2, 10mm diameter holes in the cut-out section for a start/stop point for the body saw, using the body saw cut the main hole in the guard panel, cutting through both the flare and guard panel in the lower section of the hole as marked from the template cut-out in step 7.

Hint: Vehicles fitted with factory flares, tape the flare and guard panel joint to prevent any metal filings from becoming trapped between the flare and guard seal.

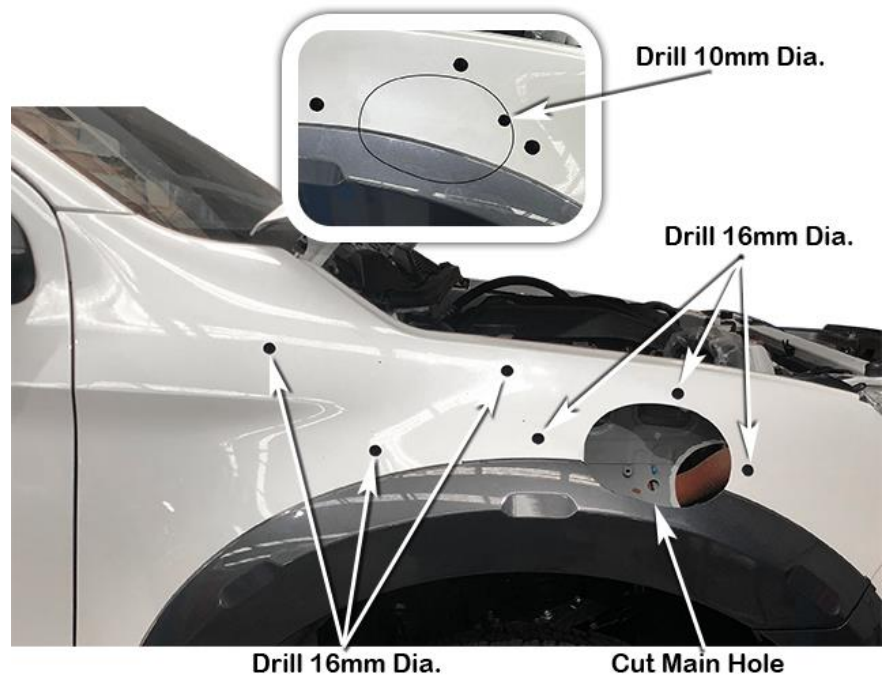

Using a sharp knife or chisel remove the sound deadening pad from behind the rear most 16mm diameter mounting hole (if required).

Ensure to remove enough of the pad from around the 16mm hole to allow the 8mm body washer (item 8) to sit flat against panel.

Deburr and paint the main hole cut-out and the six 16mm diameter holes.



Apply Sikaflex adhesive sealant to the gap between fender panel and flare.

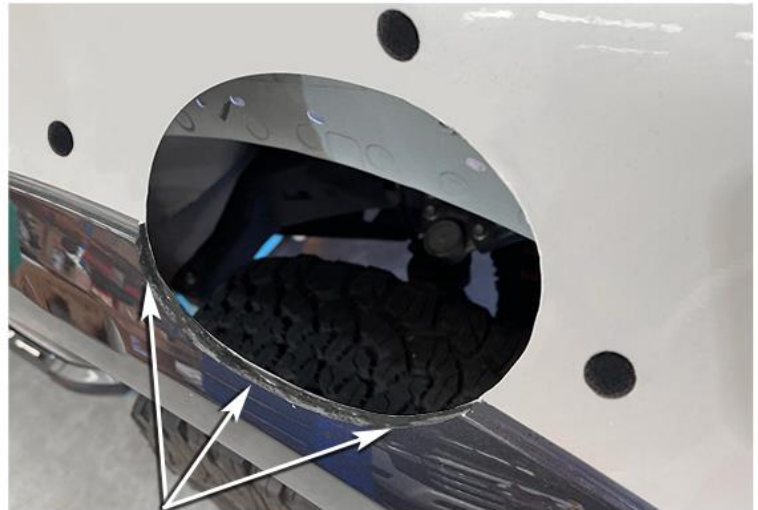

Apply Sikaflex

NEW ZEALAND INSTALLATIONS ONLY :

Safari have developed 2 methods of Snorkel A pillar attachment, for the conventional method please proceed with the current document alternatively please see the link below for further instructions.

www.safari4x4.co.nz/apillarmounting

Install the upper mounting bracket (Item 3) to the snorkel body (Item 1) with hex bolts (Item 4).

Apply Loctite 243 to each of the stainless steel mounting studs (Item 7) and install the studs finger tight into the snorkel body (Item 1) mounting inserts as shown.

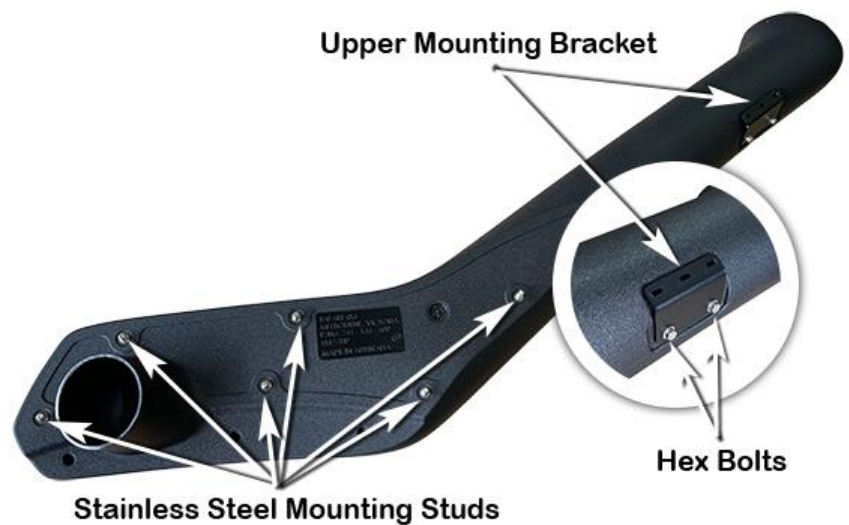

12

Locate the four dimples around the inlet of the Snorkel body.

Drill a 2.0mm pilot hole at each of the four dimple locations as shown.

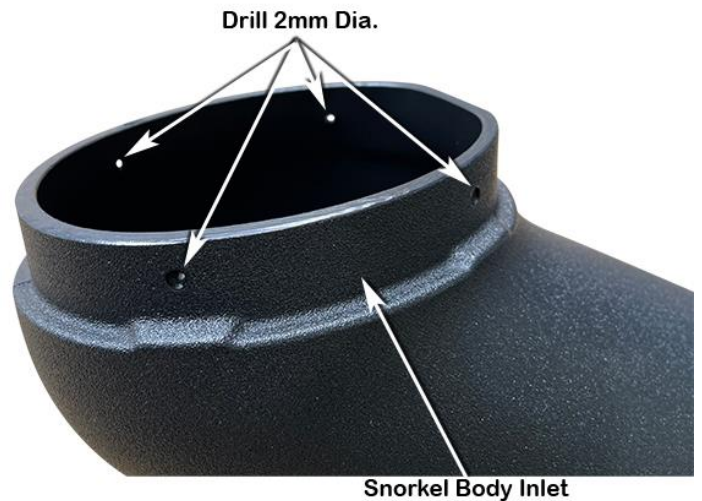

13

Non-Factory Flare Model Vehicles Only:

Apply Sikaflex adhesive sealant to the lower section of the snorkel body as shown.

Install the fender infill rubber (item 21) to the snorkel body (item 1), tape the infill rubber to the snorkel body in several positions to hold the infill rubber in position while the adhesive sealant cures.

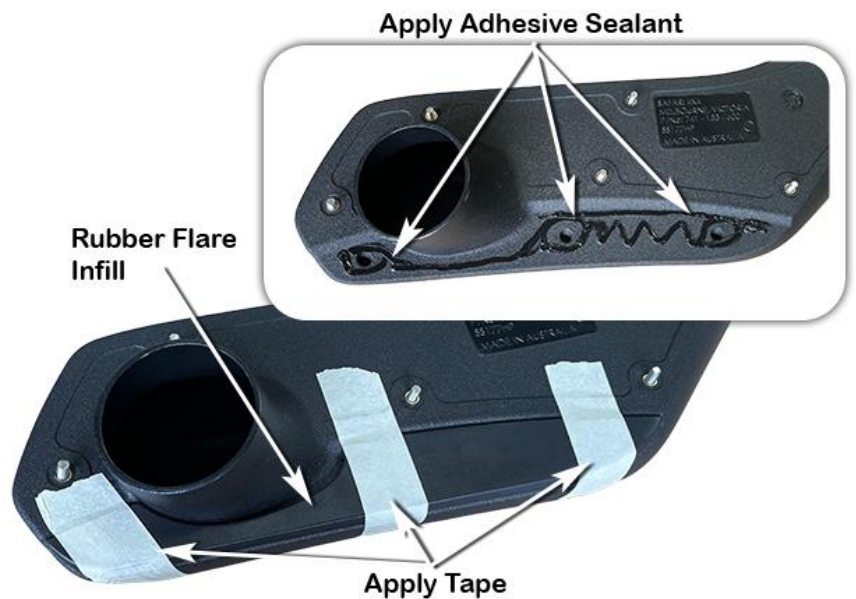

14

Place a strip of masking tape along the A-pillar panel.

Carefully install the snorkel body (Item 1) to the guard panel.

With the snorkel body correctly positioned, mark the outline of the upper mounting bracket (Item 3) onto the masking tape.

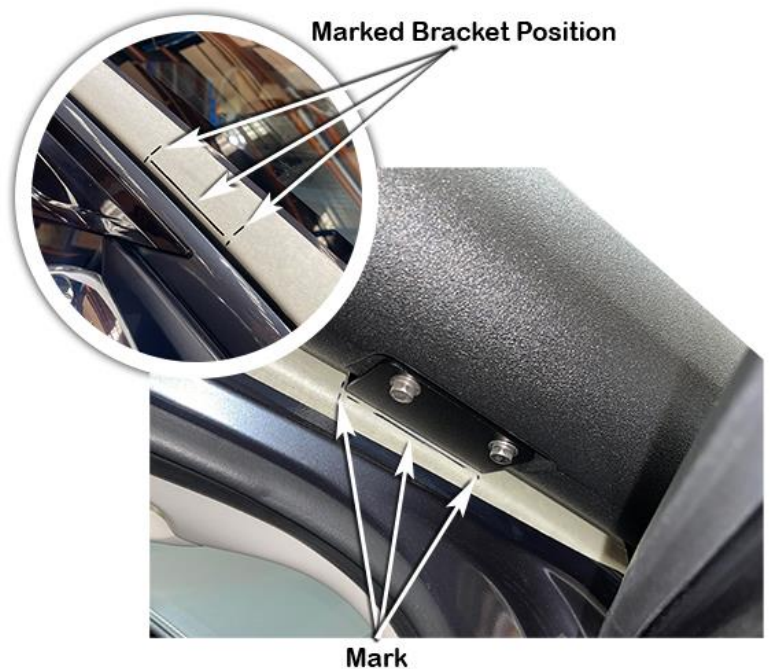

15

Remove the snorkel body (Item 1) from the vehicle and remove the upper mounting bracket (Item 3) from the snorkel body.

Position the upper mounting bracket (Item 3) onto the A-pillar and align the bracket with the marked bracket outline.

Mark the three mounting hole positions with a felt tip pen.

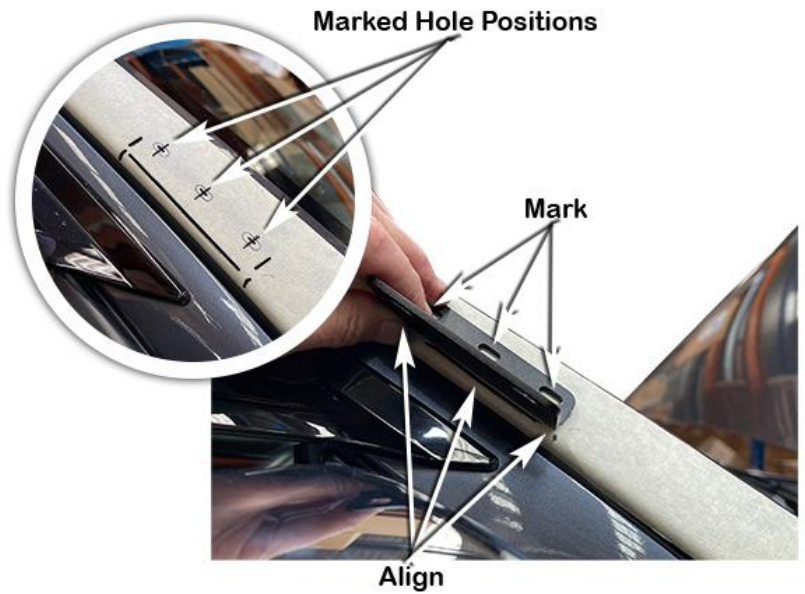

16

Drill a pilot hole at centre of each of the three marked slot / hole positions. Drill each hole position to 8mm diameter with a step drill or 8mm drill bit.

Deburr and paint holes to prevent rust.



17

Install the plastic inserts (Item 6) into the 8mm diameter holes in the A-pillar.

Secure the upper mounting bracket (Item 3) to the A-pillar with three self-tapping screws (Item 5).

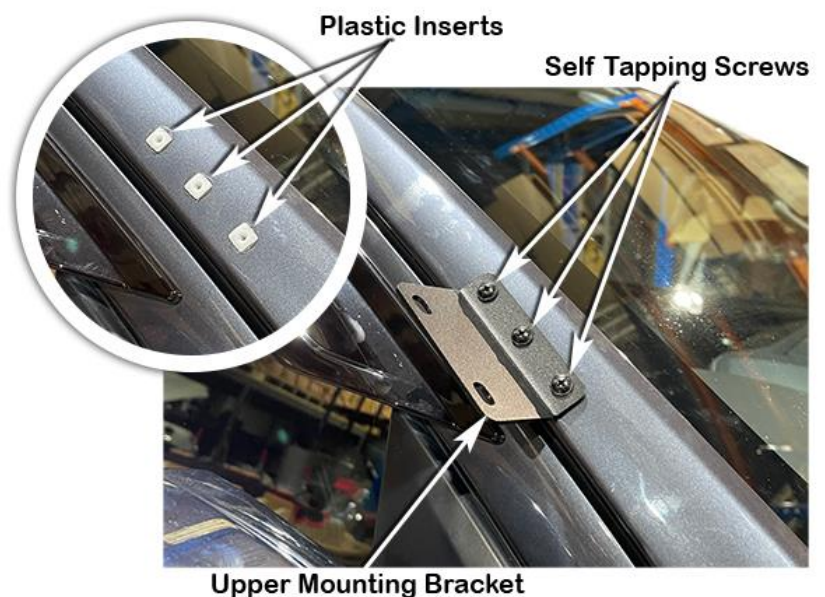

Unclip the wiring loom from its mounting positions and tape.

Align the Inner Guard Cut-out Template (Item 22) to the M6 captive nut, 16mm diameter hole and the front 6mm diameter hole of the inner guard panel as shown.

Secure template into position using 6mm bolts and masking tape where required. Ensure the template follows the contours of the inner guard panel.

Mark the required hole cut-out.

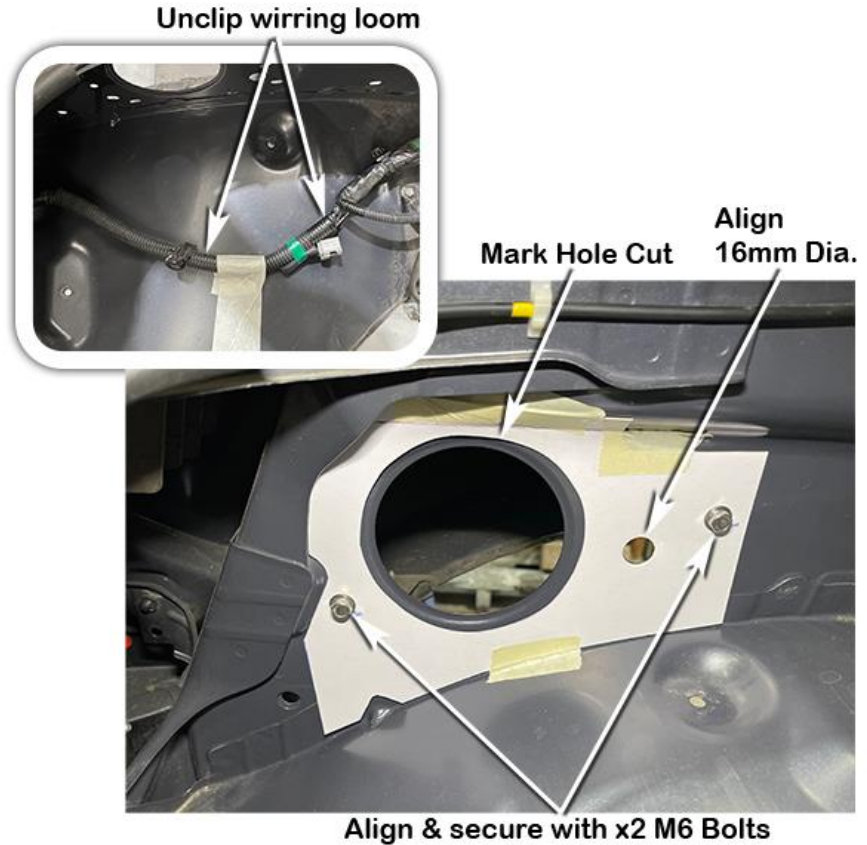

Remove the Inner Guard Cut-out Template (Item 22) from inner guard panel.

Using the body saw cut the hole in the inner guard panel, as marked from the template, using files neaten up the cut hole.

Deburr and paint the cut hole.

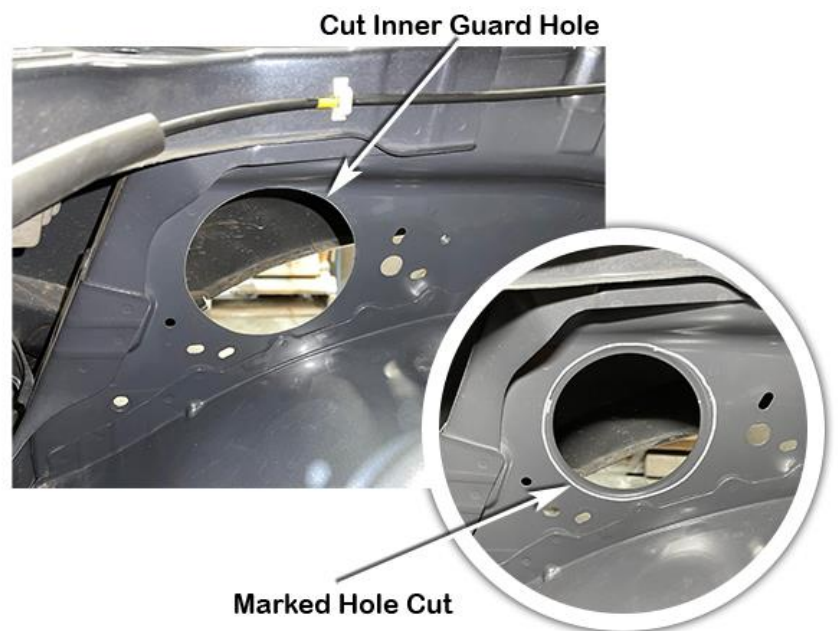

Using a grinder, sharp knife or chisel, remove the highlighted ribs and air cleaner base features from the front, side and underside of the air cleaner base, as shown.

The three underside ribs should have 25mm approximately of ribbing remaining on the airbox from the closest underside rib, after removal.

N.B: Extreme care must be taken when removing the front mounting boss from the air cleaner base.

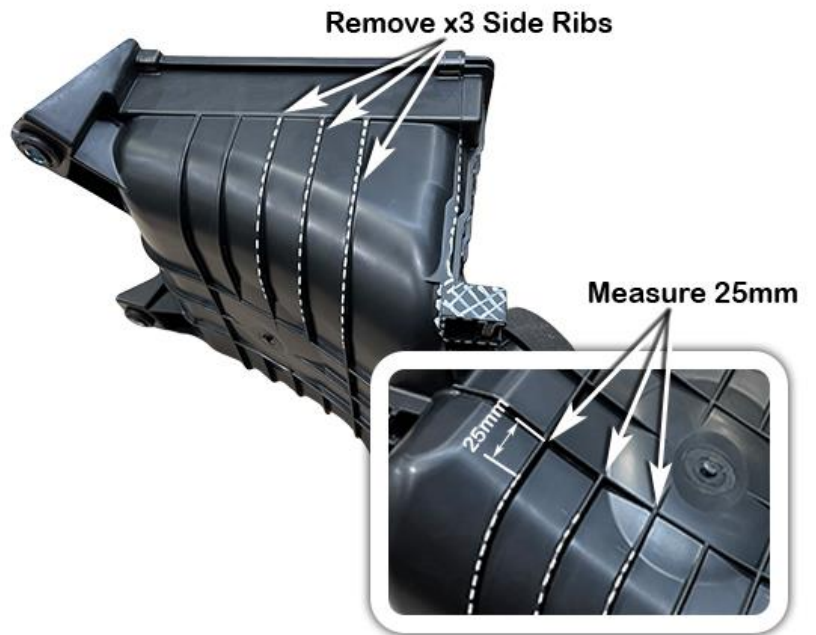

Remove the internal rib as shown.

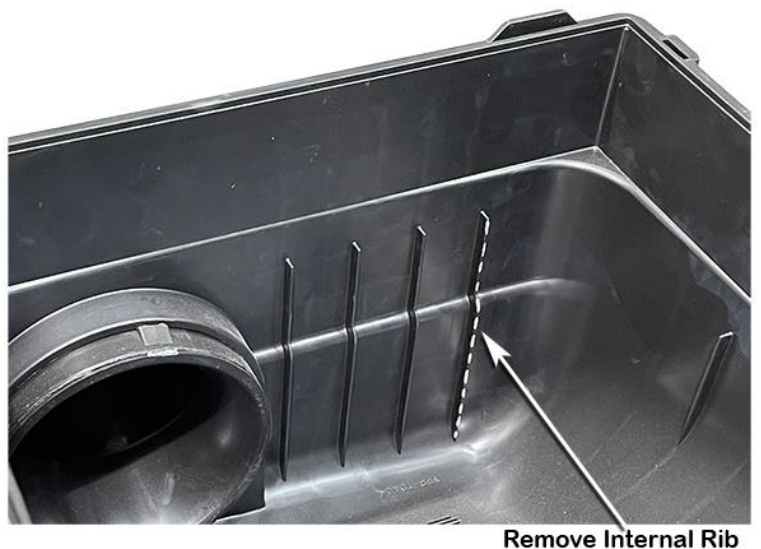

Neatly apply masking tape to the front, side and underside of the air cleaner base.

Align the main air cleaner template (item 16) under the top lip and to the side of the air cleaner clip tab, also aligning the template to the side rib of the air cleaner base as shown.

Ensure the template (item 16) follows the profile of the side rib, as shown.

With the template correctly aligned, tape the template into position with masking tape and mark all hole positions and the cutting line with felt tip pen (fine point).

Remove the template.

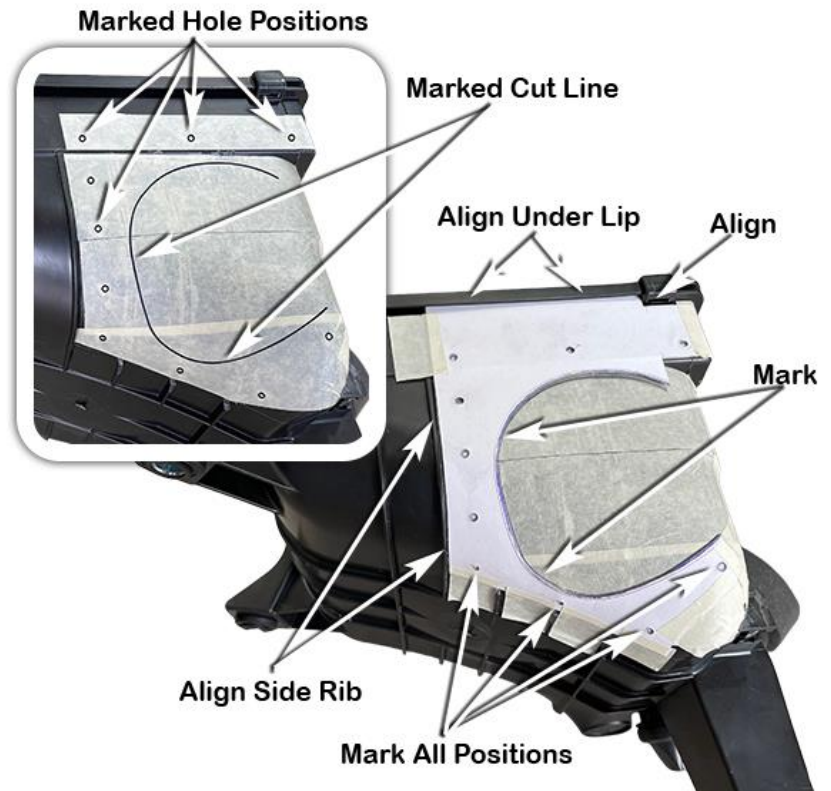

Align the front air cleaner template (item 17) to the upper and side ribs of the air cleaner base as shown.

With the template correctly aligned, tape the template into position with masking tape and mark all hole positions and the cutting line with felt tip pen (fine point).

Remove the template.



Drill a pilot hole for each of the sixteen marked mount hole positions.

Drill each hole position to 4.5mm diameter.

Using the body saw cut the new air inlet hole as marked from the templates in steps 22 & 23.

De-burr all sixteen holes & the new air inlet hole cut section.

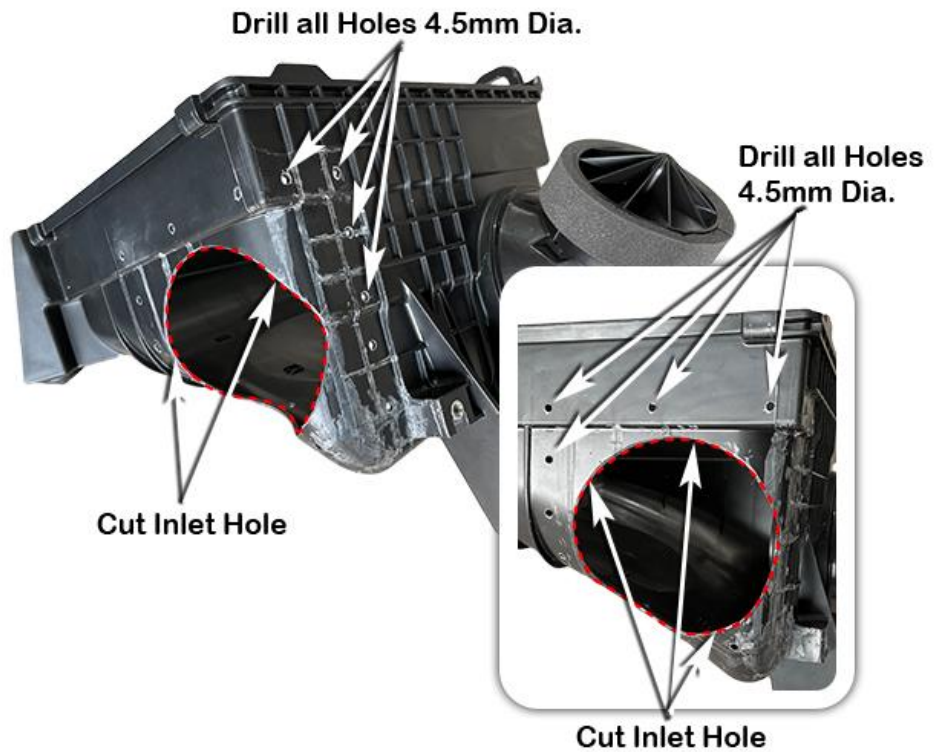

Pre-bend one of the hose support plates (Item 11) to the required hose profile as shown.

Pre-bend the lower hose support plate (Item 13) to the required hose profile as shown.

Hint: Use a vice and a small hammer to bend the support plates to the required hose profile.

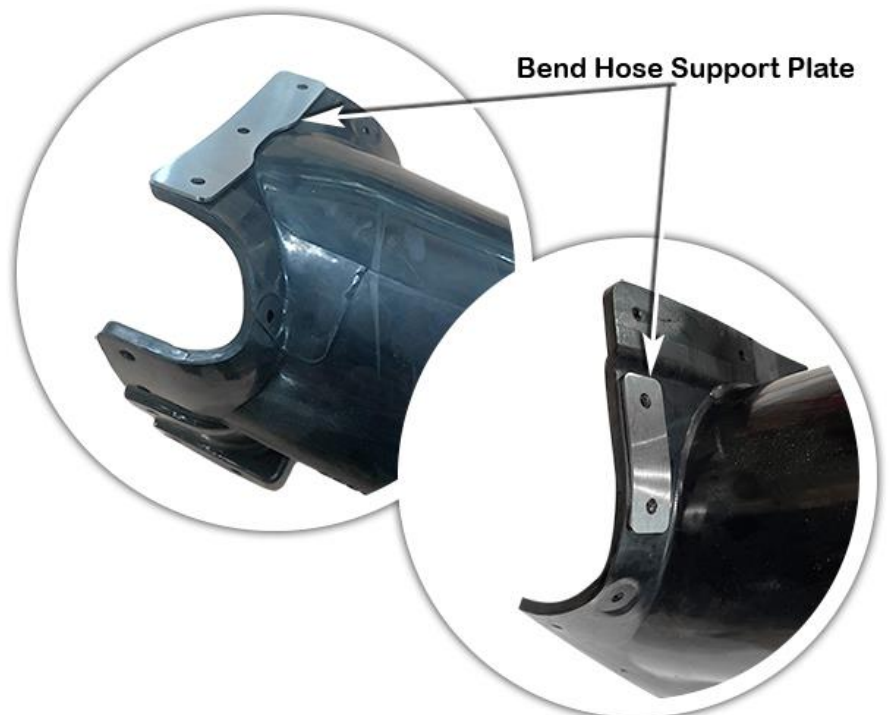

Apply Sikaflex adhesive sealant to the mating surfaces of the air cleaner base and air entry hose flange (item 10).

Install the air entry hose to air cleaner base.

Install and secure pop rivets (item 14) and hose support plates (item's: 11,12 & 13) as shown.

Install an M4 body washer (item: 15) onto the two lower corner pop rivets as shown.

Clean-up any excess sealant to ensure a neat finish.

N.B: All pop rivets must be installed from the inside of the air cleaner base.



Remove and discard the foam seal from the standard air cleaner inlet.

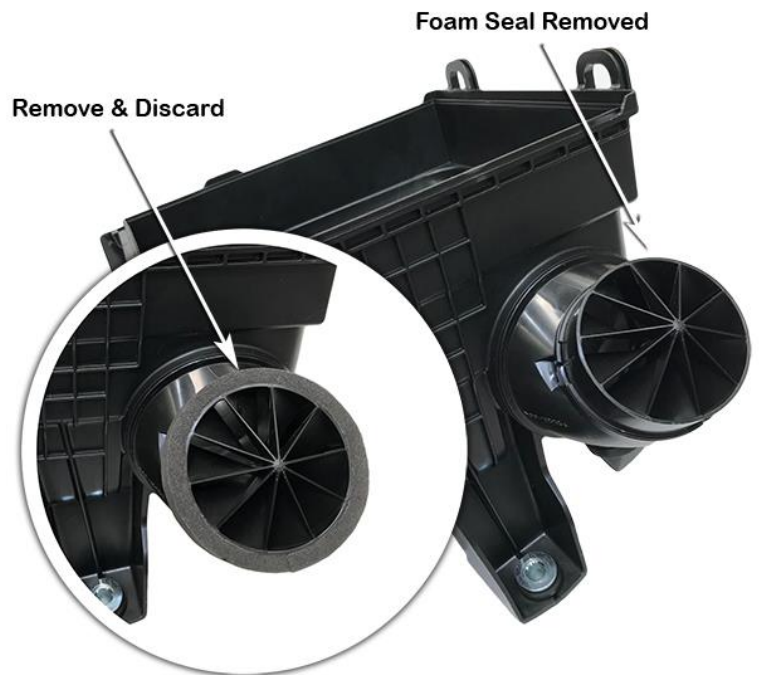

The standard air cleaner inlet must be sealed by the installer.

Carefully dismantled the air cleaner inlet from the air cleaner base, remove and discard the foam seal.

Apply Sikaflex adhesive sealant to all the joints and then reassembled.

Clean-up any excess sealant to ensure a neat finish.

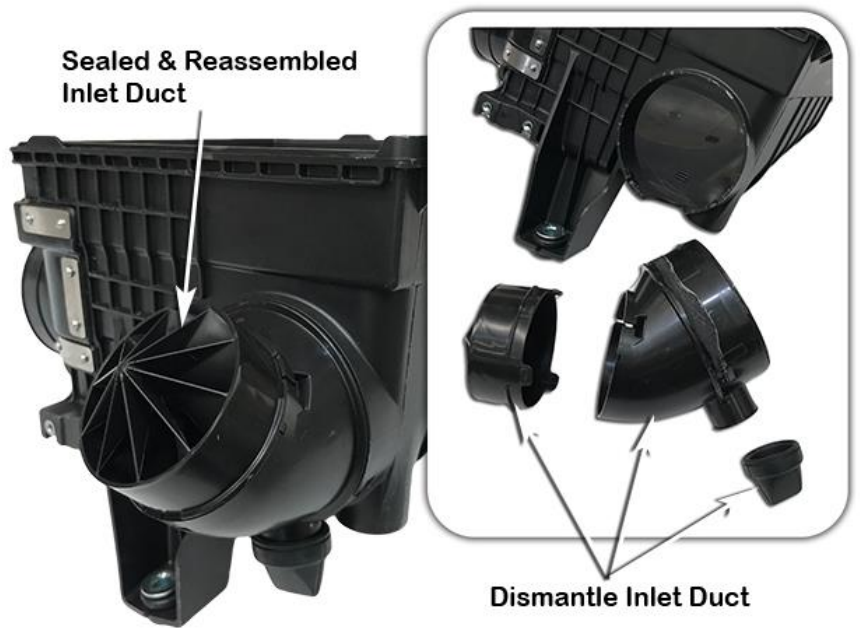

INSTALLER OPTION :

The air cleaner housing base contains two drain valves as shown. The drain valves can permit water to enter the air intake.

Safari advises that the drain valves should be sealed to ensure a watertight installation.



Install the moulded rubber blank-off cap (item 18) to the standard air cleaner inlet.

Install a 70/90mm hose clamp (item 19) onto the blank-off cap and fasten the hose clamp.



The end of the air entry hose (item 10) must be squashed inwards and taped to hold in position as shown.

N.B: it is critical the hose is taped the way shown in the photo, for installation purposes.



Re-install the air cleaner base into position, guiding the air entry hose through the hole in the inner guard panel. Once the air cleaner base is correctly positioned, install the three standard mounting bolts and fasten.

Remove the tape from the end of the air entry hose.

Loosely install the 100/120mm hose clamp (item 20) to the inlet of the air entry hose (item 10).

Note: The orientation of the hose clamp.

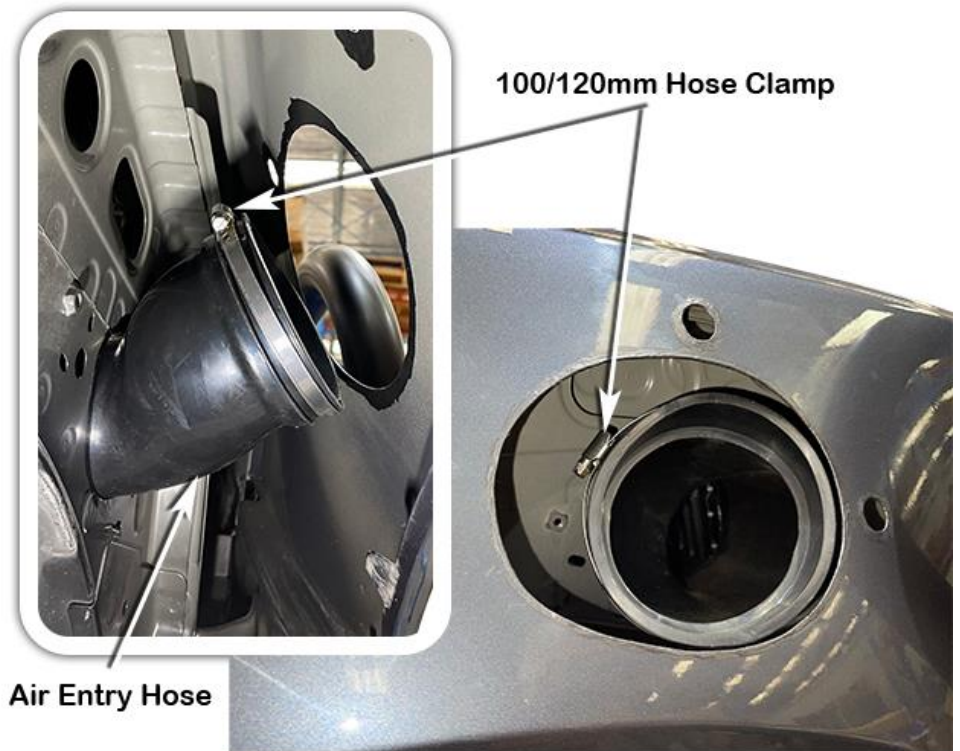

Install the ARMAX air ram assembly (item 2) onto the snorkel body.

Align the ARMAX air ram assembly mount holes with the four pre-drilled 2mm pilot holes in snorkel body inlet.

Secure the ARMAX air ram (Item 2) to the Snorkel Body (item 1) with four self-tapping screws (Item 5).



Apply a small amount of lubricant to the inside of the air entry hose (item 10).

Carefully install the snorkel body (Item 1) to the guard panel, guiding the snorkel body outlet into the air entry hose (item 10), align the snorkel body to guard panel and upper mounting bracket.

When correctly aligned, fasten the snorkel body to the guard panel with body washers (Item 8) and nyloc nuts (Item 9).

Fasten the snorkel body to the upper mounting bracket with hex bolts (Item 4).



Ensure the air entry hose is correctly installed onto the snorkel body outlet and tighten the 100/120mm hose clamp (item 20).

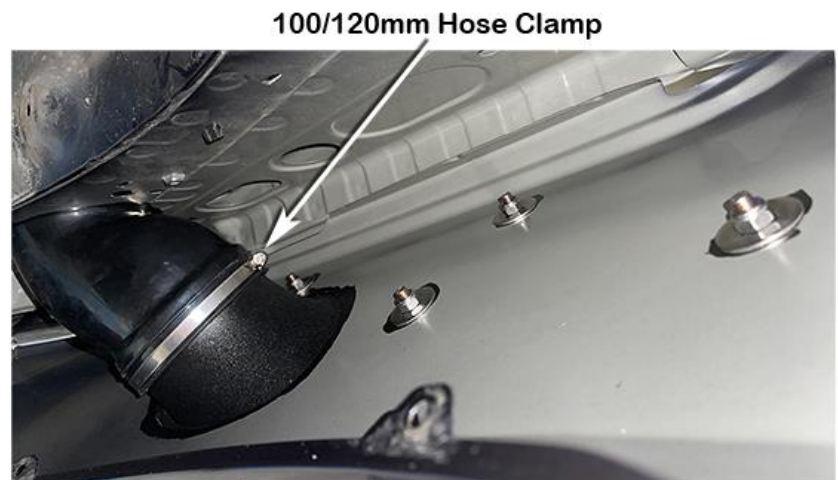

Install the RHS guard liner, mud flap, air cleaner element, air cleaner lid, reconnect sensor wiring and any other items that may have been removed during the snorkel installation process.

N.B: It is the installer's responsibility to ensure that all connections are water tight.