



ARMAX

SMIGUN125A2

**Toyota Hi-Lux 125 Series 1GD-FTV (150kW i-ART)
04/2020-to Current and
Toyota Fortuner 155 Series 1GD-FTV (150kW i-ART)
04/2020 to Current**





WARNING!!

The Safari Armax Engine Control Unit (ECU) CANNOT be used in conjunction with any aftermarket electrical device, micro controller or altered/reflashed OE control unit which influences the operation of the OE control unit and/or the operation of the vehicles drivetrain, without specific written consent from Safari 4x4 Engineering Pty Ltd, failure to seek written consent will void all claims against vehicle drivetrain warranties which Safari 4x4 Engineering offer as part of this system.

Parts List

Item	Part No.	Description	Qty.
1.	000-081-800	SAFARI ARMAX ECU	1
2.	322-283-100	WIRING LOOM	1
3.	322-283-050	WIRING LOOM - IN CAR	1
4.	000-082-000	SWITCH - 5 POSITION - ECU	1
5.	322-289-000	MOUNTING BRACKET A	1
6.	322-289-100	MOUNTING BRACKET B	1
7.	322-289-200	MOUNTING BRACKET C	1
8.	322-289-300	MOUNTING BRACKET D	1
9.	000-001-500	BOLT - M6 X 12MM - SEMS - SS	2
10.	000-001-600	BOLT - M6 X 15MM - SEMS - SS	7
11.	000-1013-400	BOLT - M8 X 25MM - SEMS - SS	2
12.	333-189-500	SPACER - 5MM	1
13.	000-302-100	WASHER - FLAT - M8	1
14.	000-205-300	NUT - NYLOC - M8	1
15.	000-987-290	TIE - CABLE	14

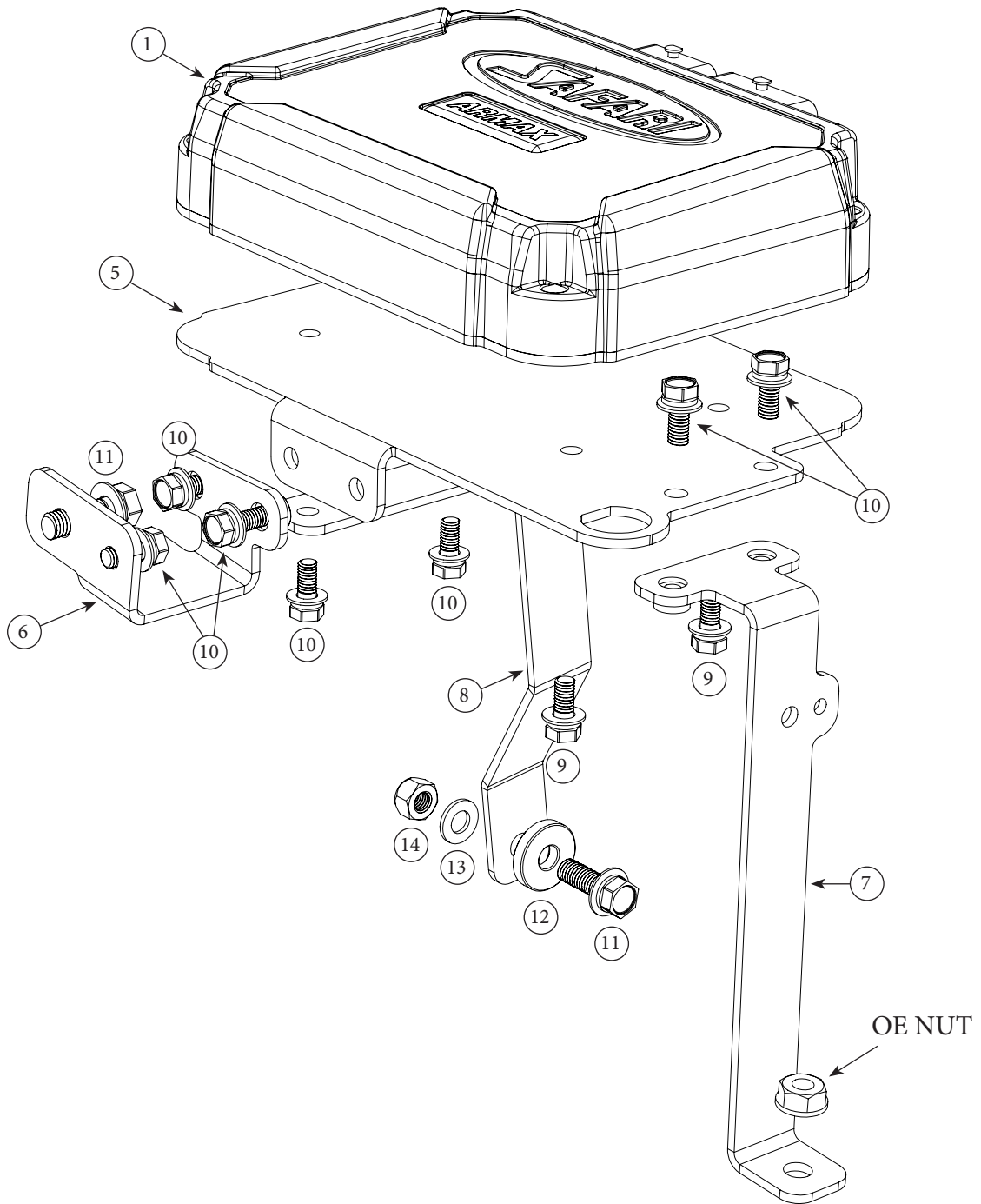

ARMAX ECU Mounting Bracket Diagram

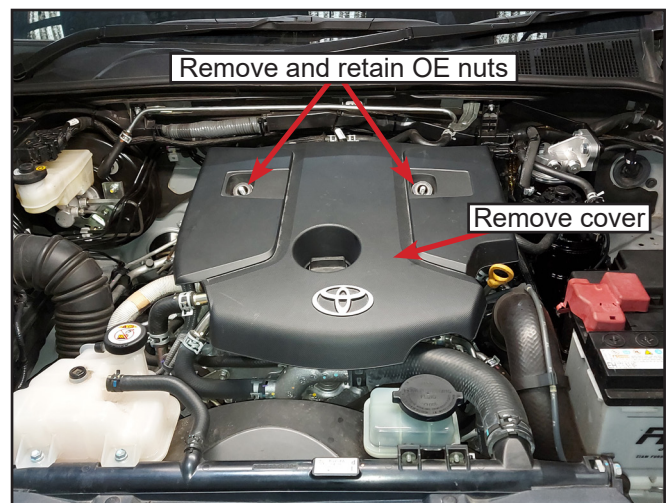

1.

Remove engine cover.

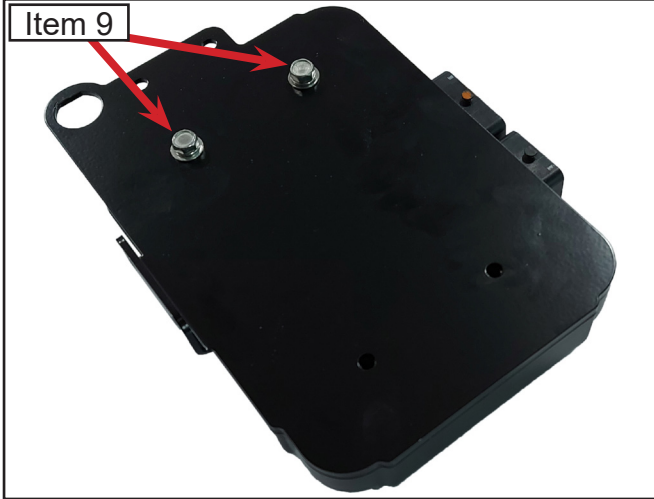
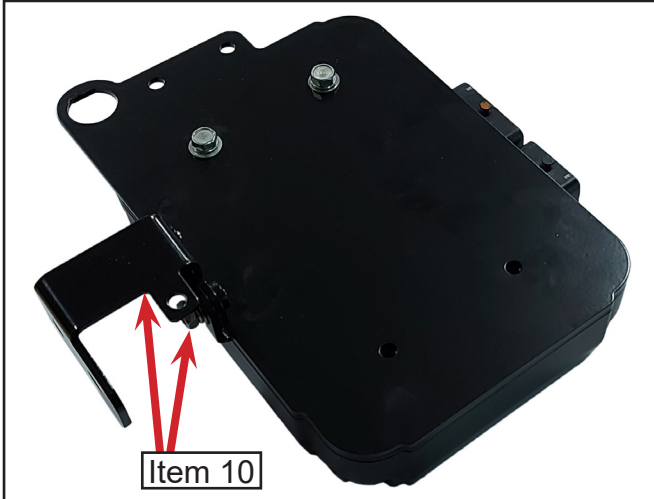

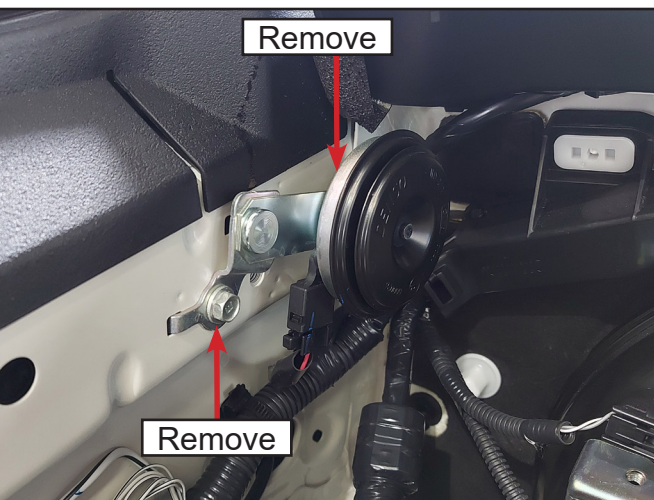
<p>2.</p>	<p>Identify ECU mounting plate (Bracket A) and install Safari ARMAX ECU using 2 x M6x12mm SEMS bolts (Item 9) in orientation shown.</p>	
<p>3.</p>	<p>Install side support bracket (Bracket B) to ECU mounting plate (Bracket A) using 2 x M6x15mm SEMS bolts in orientation shown.</p>	
<p>4.</p>	<p>Install front support bracket (Bracket C) to ECU mounting plate using 2 x M6x15mm SEMS bolts (Item 10).</p>	
<p>5.</p>	<p>Remove the horn from its bracket and retain OE nut. Remove the horn bracket and discard.</p>	

6. Take note of side support bracket (**Bracket B**) mounting locations where horn bracket was removed.

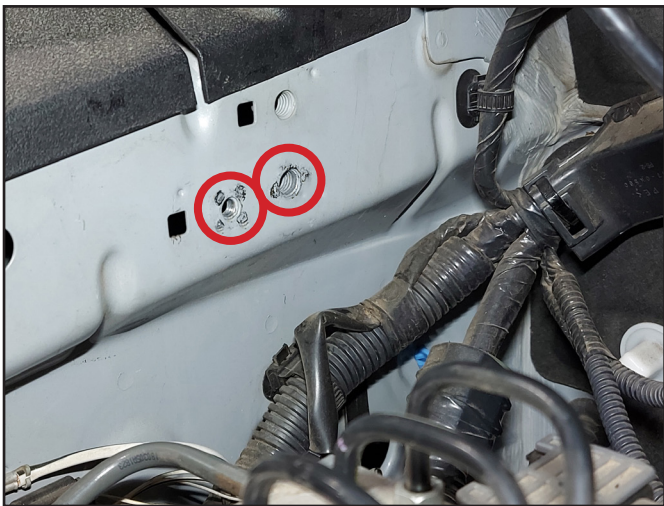

7. Remove and retain inboard nut from ABS unit.

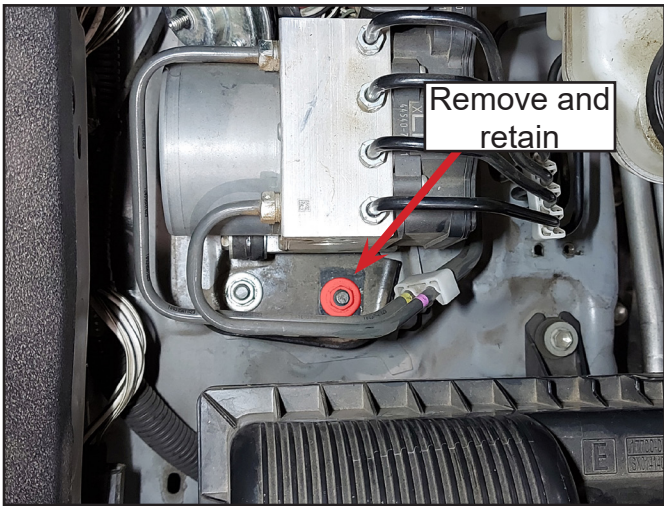

8. Take note of rear support bracket (**Bracket D**) mounting point located lower left side of brake master cylinder.

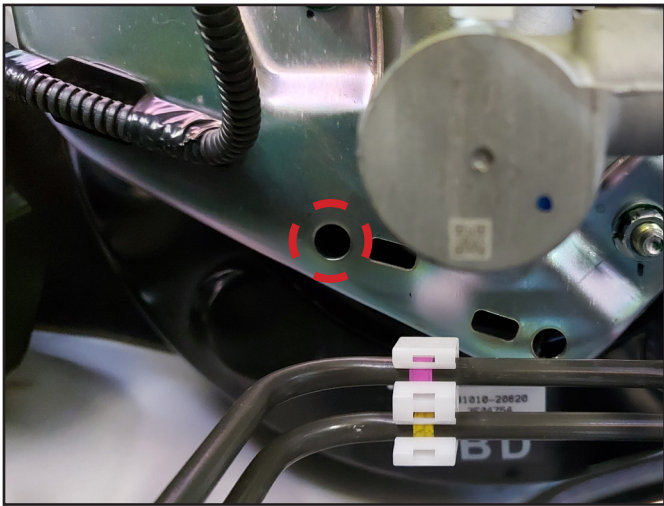

9. Remove wiring loom clip and both master cylinder nuts, then remove bracket from booster.

- Retain both OE nuts

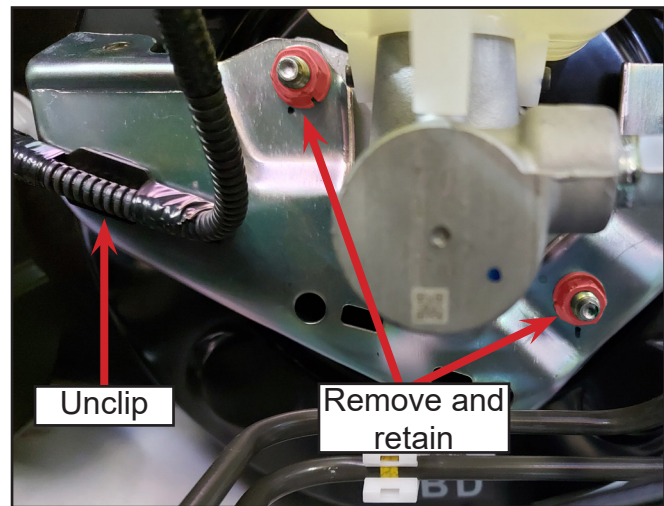

10.

Install rear support bracket (**Bracket D**) to mounting point on brake booster bracket using **M8x25mm SEMS bolt (Item 11)**, **5mm spacer (Item 12)**, **M8 flat washer (Item 12)** and **M8 nyloc nut (Item 13)**. Refer to diagram on page 3

- Do not fully tighten

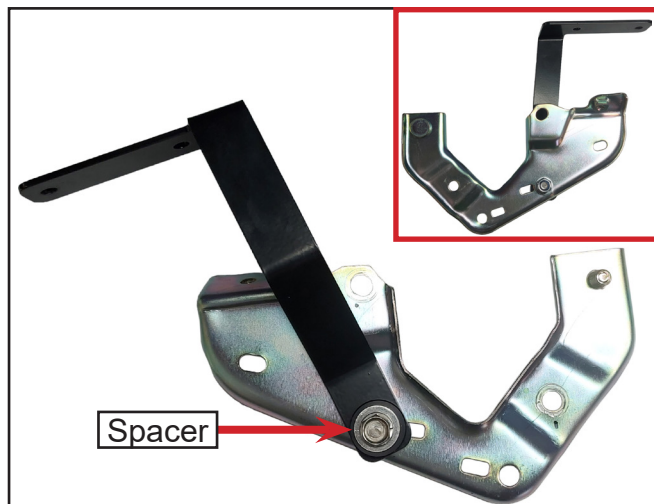

11.

Install the OE bracket to brake booster and tighten retained OE nuts.

Clip wiring loom back in position.

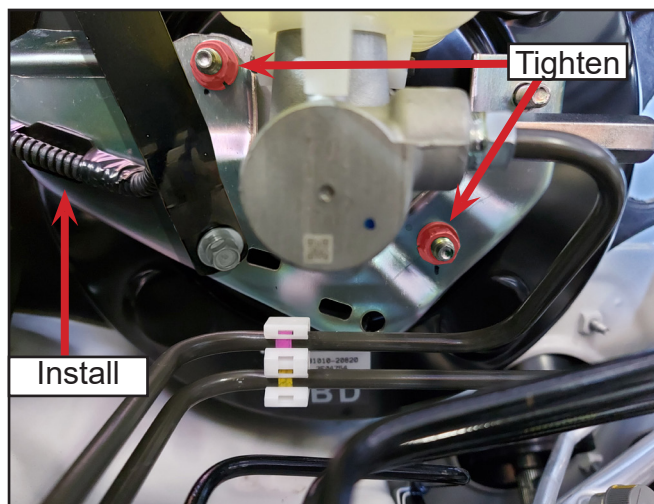

12.

Install ECU and bracket assembly (**step 4**) over ABS unit and locate front support bracket (**Bracket C**) onto ABS mounting stud shown.

The retained ABS nut can be installed after the next couple steps.

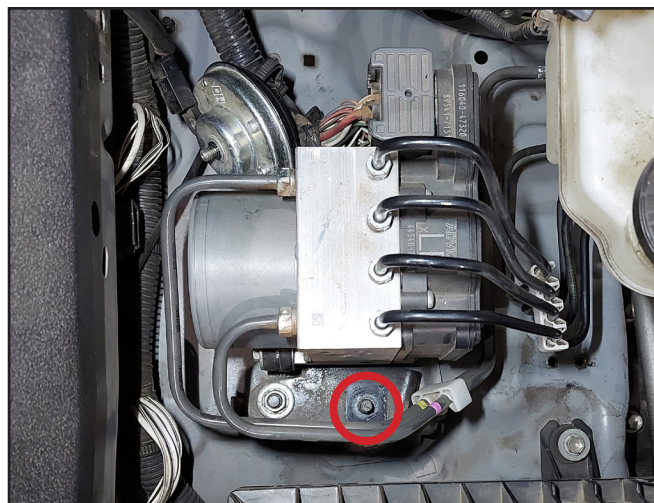

13.

Secure **Bracket D** to ECU assembly using **2 x M6x15mm SEMS bolts (Item 10)**.

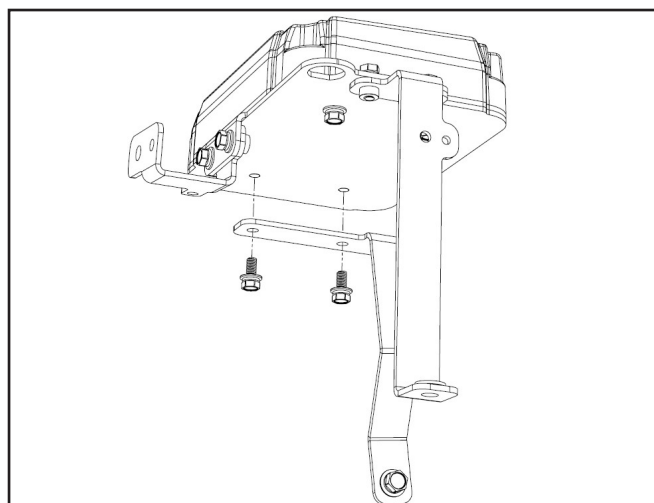

14.

Install side support bracket (**Bracket B**) mounting bolts.

- Rearward bolt M8x25mm SEMS (1 x item 11)

- Forward bolt M6x15mm SEMS (1 x item 10)

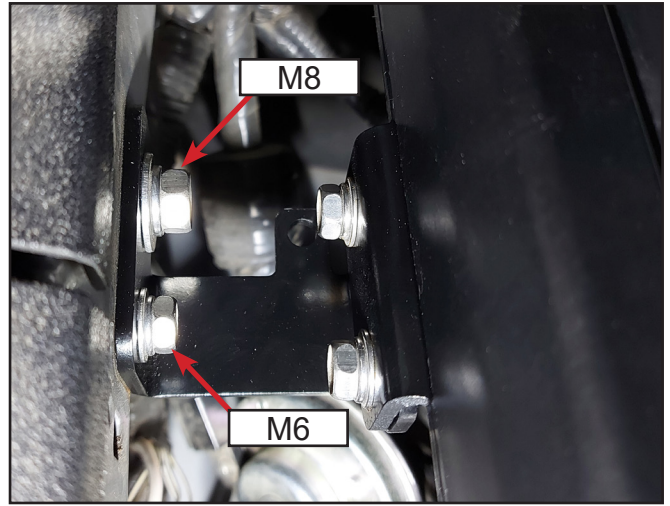

15.

Install retained OE ABS unit nut to front support bracket.

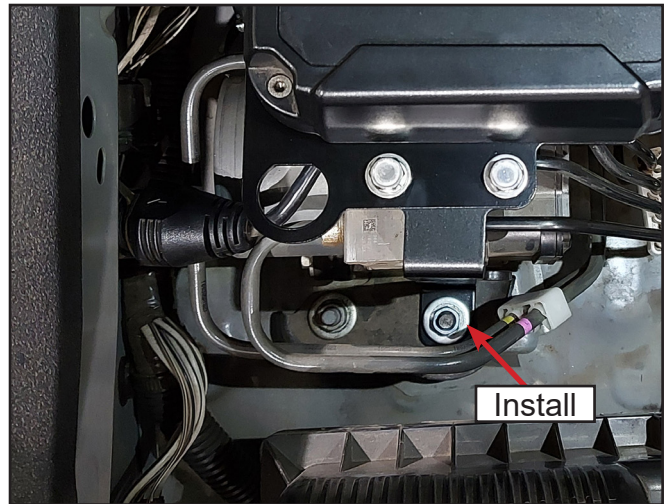

16.

Tighten rear support bracket (**Bracket D**) mounting bolt and nut.

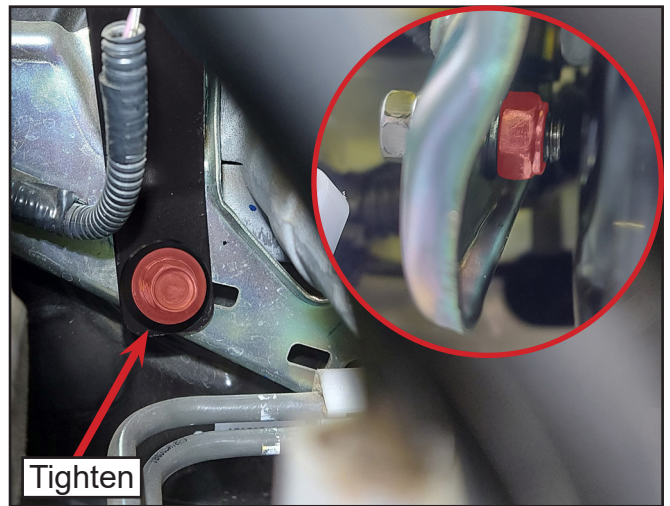

17.

Identify horn mounting location on side support bracket.

- Install horn using retained OE nut

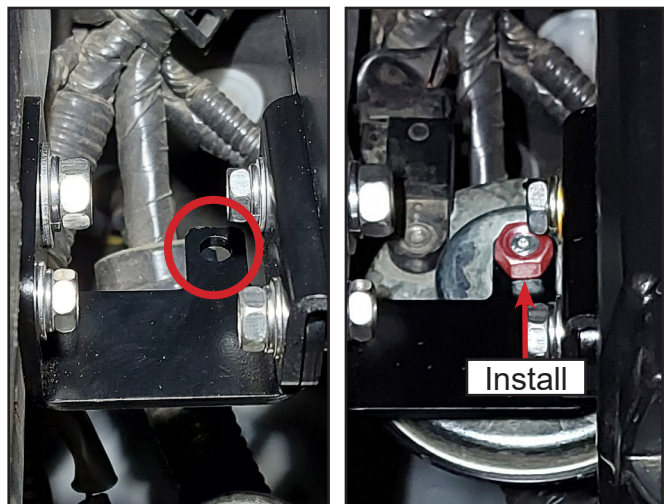

Install Safari wiring loom and route as shown below (item 2).

Route behind brake booster vacuum hose.

Connect ECU header connectors.

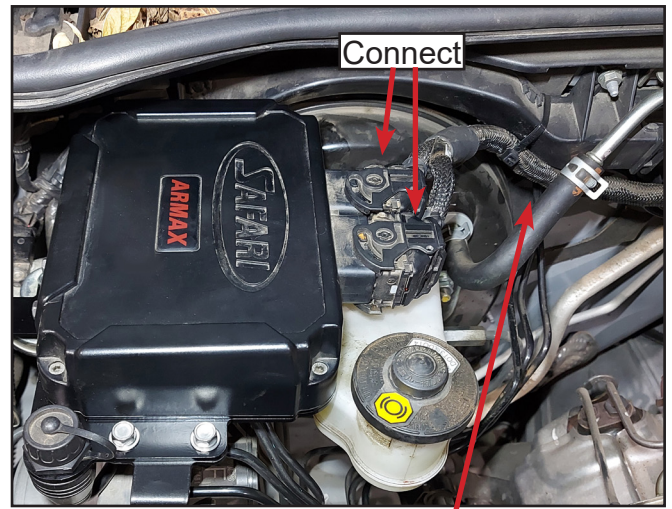

1. Push down
2. Rotate arm
3. Lock arm

Red: ARMAX wiring harness

1. Communication port.
2. In car loom
3. Fuel injectors
4. EGT sensor connector
5. MAP sensor
6. Batt. positive and ground

- Do not connect to battery at this stage.

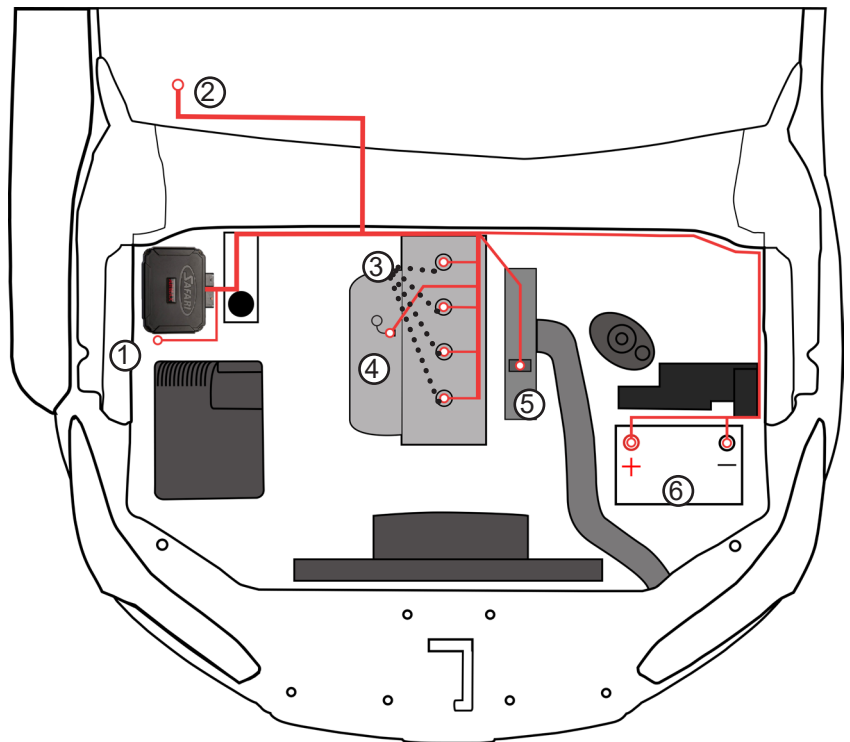

19.

Connect the ARMAX loom to the injectors and vehicle injector connector to loom.

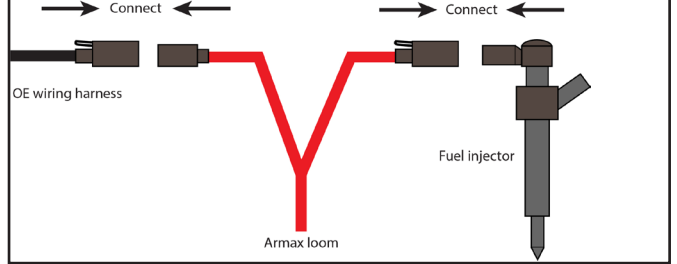
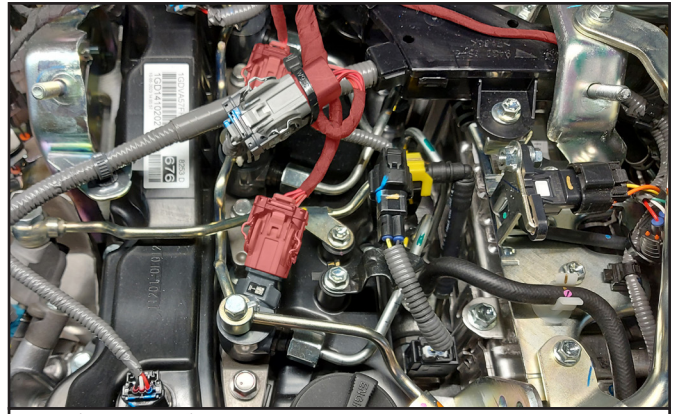
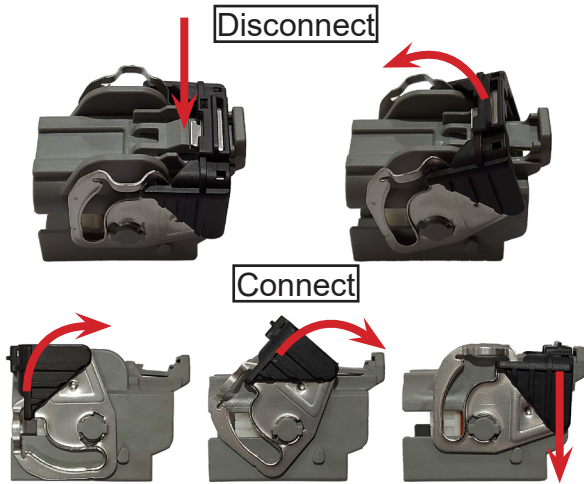

20.

Connect the ARMAX loom to MAP sensor and vehicle MAP sensor connector to loom.

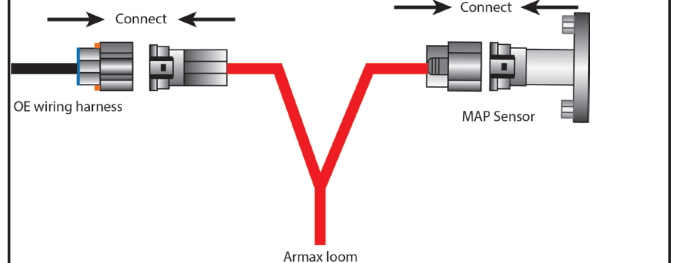

21.

Connect the ARMAX loom to the EGT sensor and the vehicle EGT sensor connector to loom.

(Vehicle's white connector)

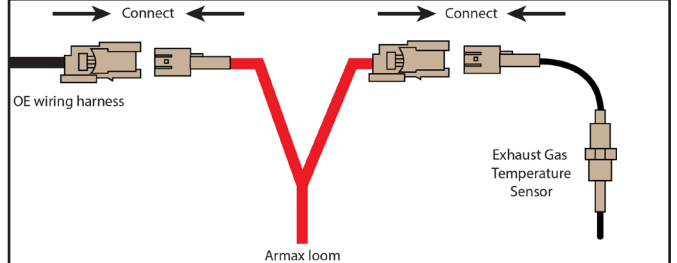
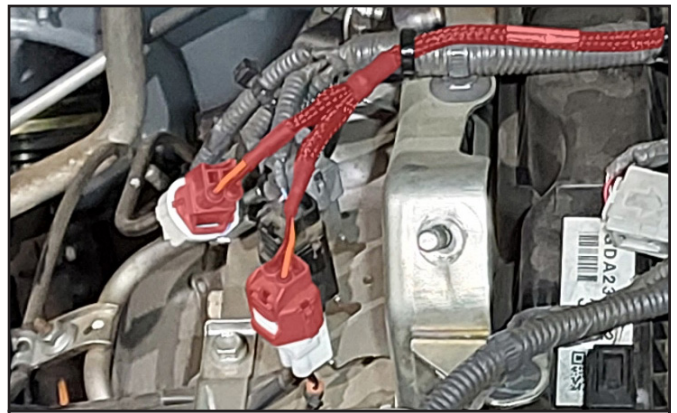

Install communication port to ECU mount plate as shown.

- Refer to diagram below

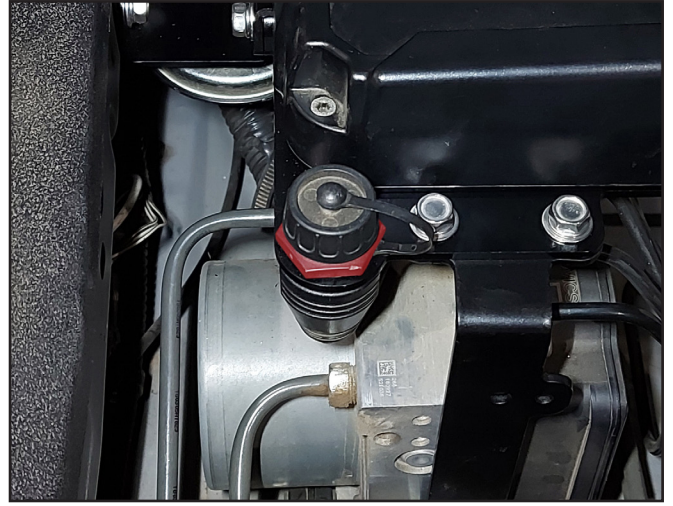

22.

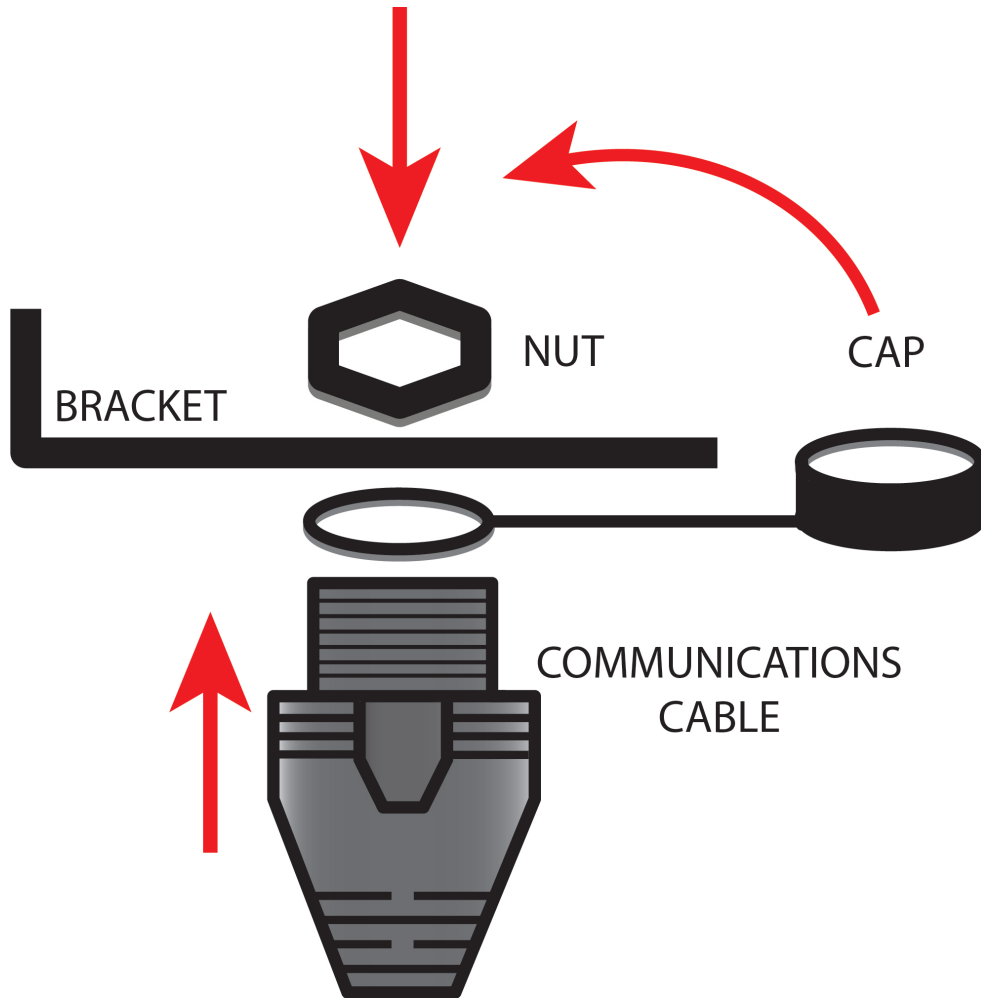

Locate OE harness firewall grommet on right hand side of brake booster.

Cut a hole and feed in car loom branch through hole.

Feed enough loom into the foot well to allow Safari harness to run along OE harness in engine bay as shown.

23.

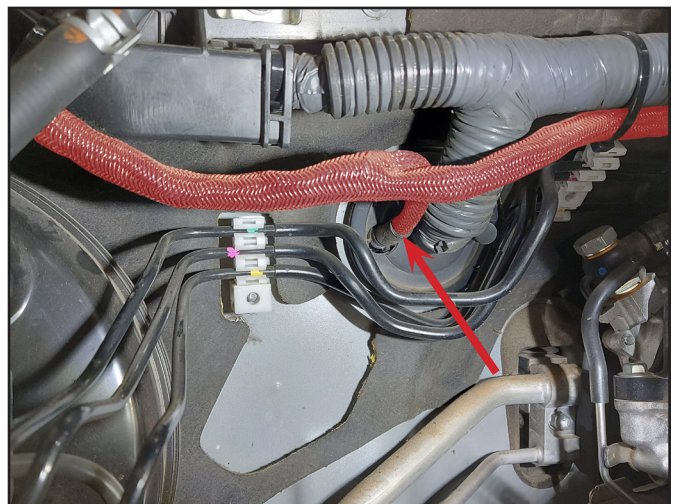

24.

Insert the in car loom terminals into the supplied 8 pin connector. Match the colours to the in car loom harness connector.

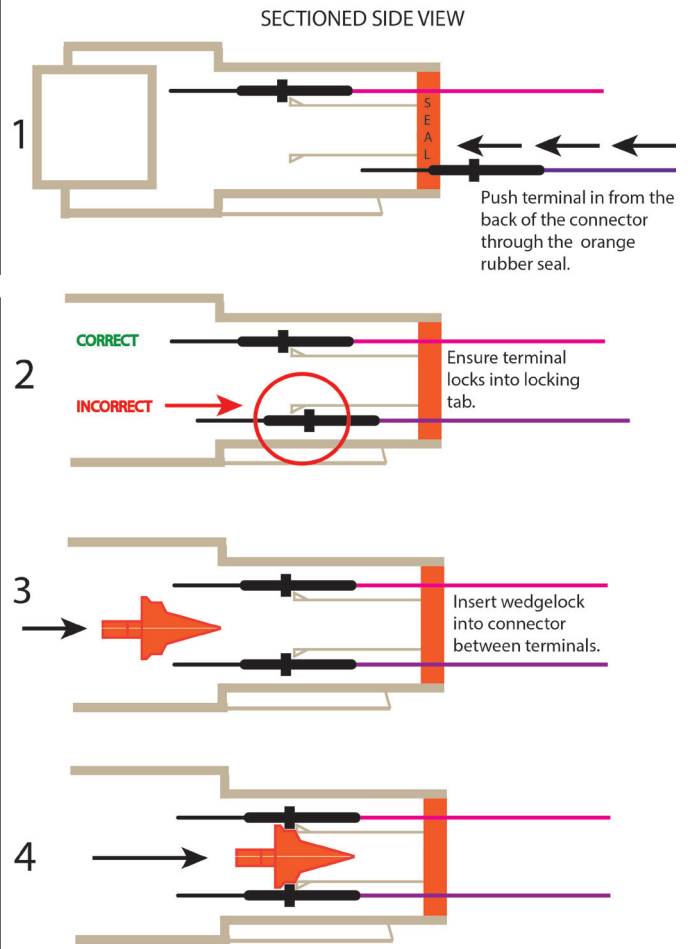
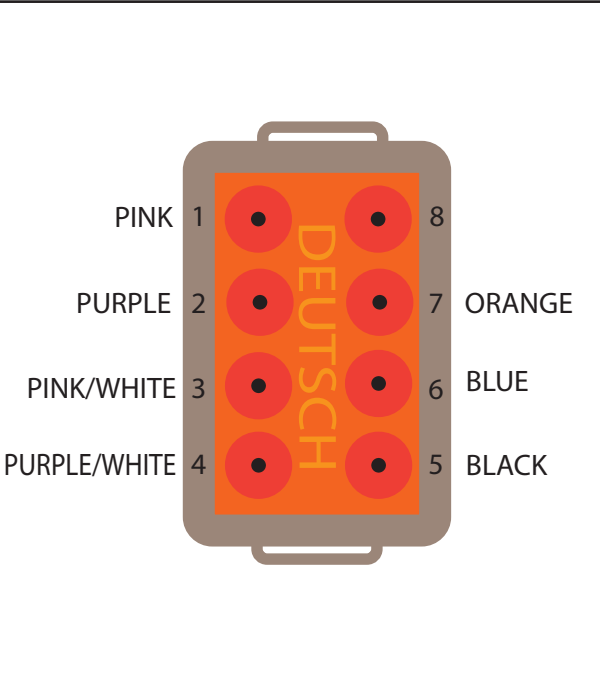

25.

Secure the in car loom to the interior harness and above the steering column in the footwell. Ensure that it is clear of the brake pedal assembly.

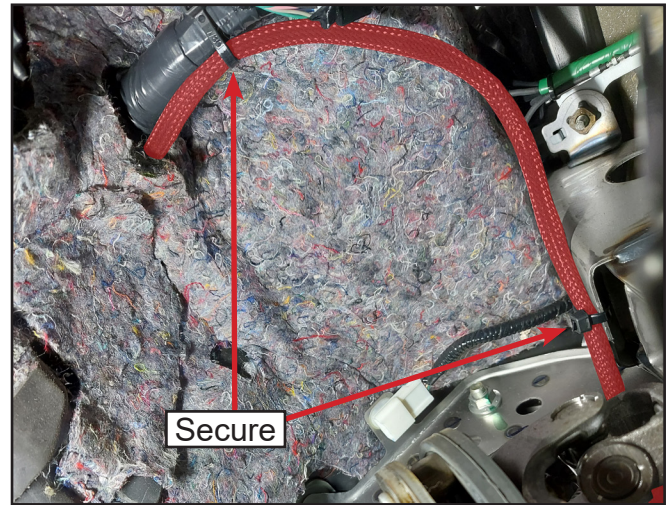

26.

Connect the in car loom to the accelerator pedal. Secure in car loom using cable ties.

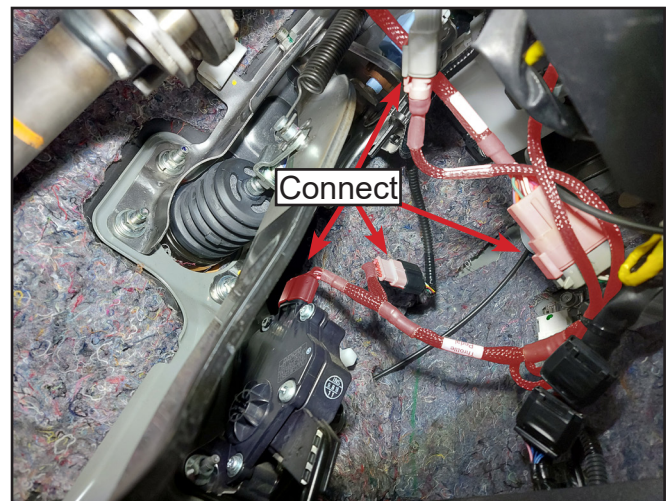

27.

Connect Map selector switch.

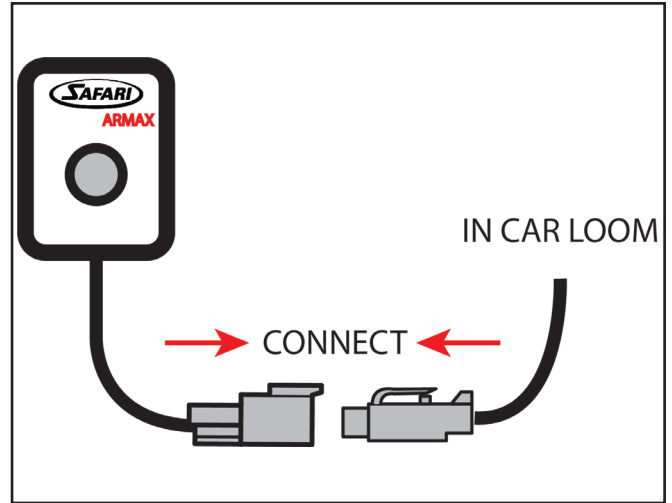

28.

Mount Map select switch in desired location.

Hold firmly in position for 60 seconds

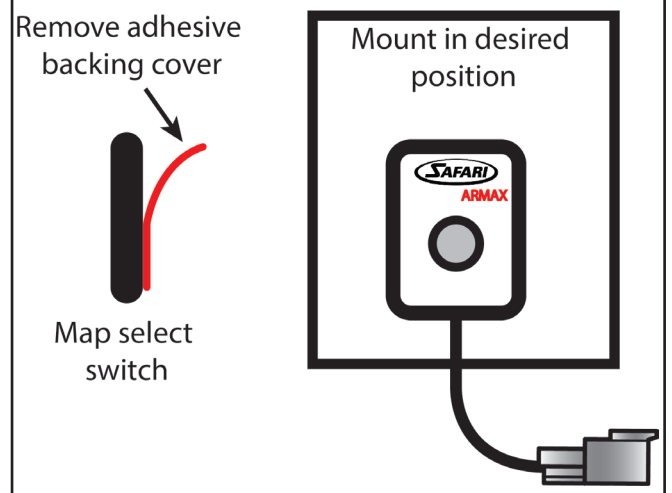

Connect Safari loom to positive and negative terminals of battery.

Secure wiring harness along firewall and to the OE wiring harness. Ensure that it is clear of Sharp edges or hot surfaces.

29.

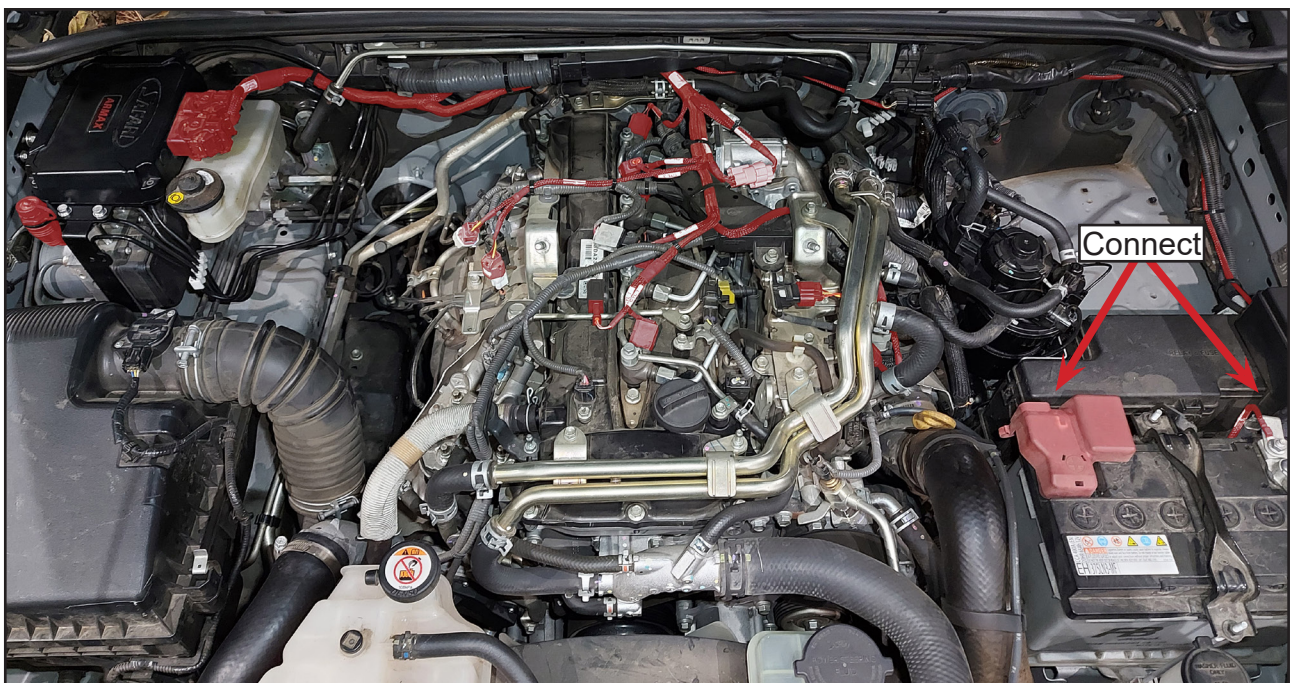

30.

Final fitment checklist:

- Check all ECU mounting hardware is tight.
- Check the loom is secure and not in contact with the engine or exhaust.
- Check all connections are correct.
- Check the Armax ECU diagnostics.
- **Place the user manual and bridge out connector in the glove box of the vehicle.**

31.

Re-install engine cover.



32.

Test drive checklist:

- Start vehicle and ensure there are no engine/warning lights.
- Check that the engine is operating as normal (not misfiring/making unusual sounds).
- Check that the switch illuminates and cycles through the different maps
- Drive the vehicle ensuring it reaches full operating temperature (the ECU will not operate at its full potential until this is reached). Drive the vehicle on different maps and check that the ECU operates correctly.

33.

Record a log file of the vehicle and E-Mail it to: Support @Safari4x4.com.au so the file can be checked and approval given for the vehicle to be released to the customer.